

Façades in Architecture: History and Development

Arch 173: Building Construction 2

Façade – definition

Noun:

The face of a building, especially the principal front that looks onto a street or open space

Your choice of skin/ façade will be **CLIMATE
DEPENDENT**

The type of building – commercial,
institutional, residential matters

The amount of insulation needed responds to
both climate and building use

The façade or skin is a huge part of the budget

Every façade we will look at, think about:

1. Composition
2. Performance
3. Light

Composition

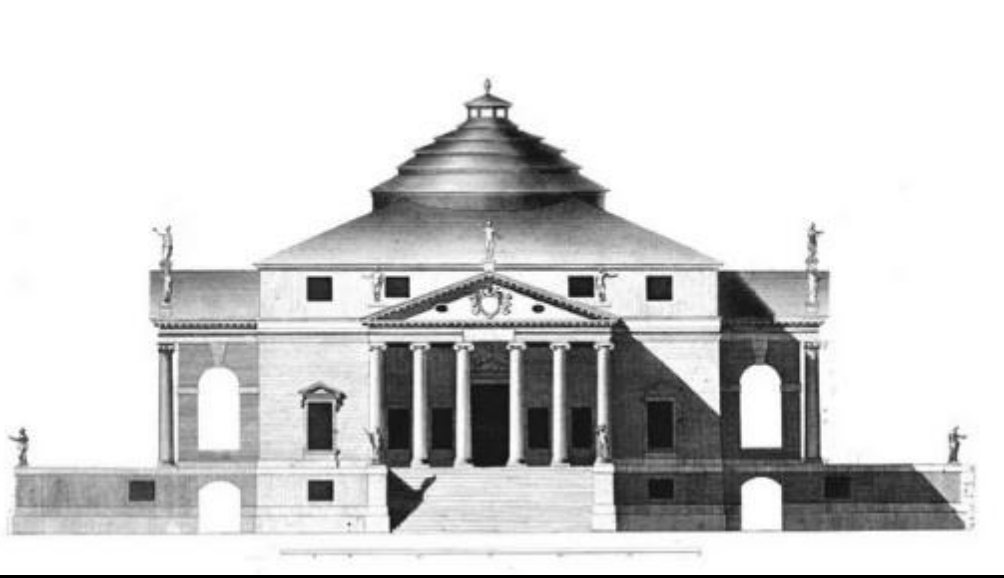

More formal to less formal

Performance



From defence to energy

Light



More light a function of separation of structure and envelope
Cost of glass goes down dramatically over time

Façade vs. Enclosure??

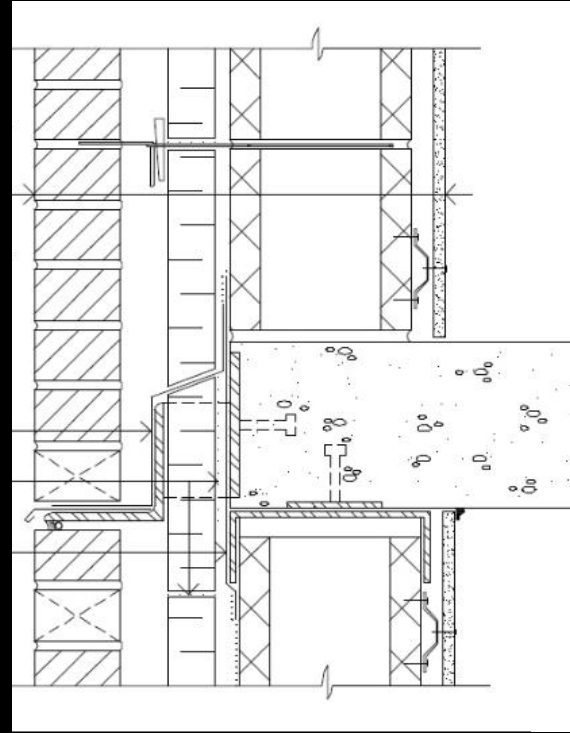

Appearance vs. Performance

Questions to ask:

1. What does your building want to say (human)?
2. What does your building need to DO (technical)?
3. Where do you want light & views, solid, privacy"
4. What existing technologies will fit these needs"

In Architecture and Engineering

PERFORMANCE is the goal!

- Climate responsive
- Energy efficient
- Durable
- Low carbon
- And yes, aesthetically pleasing



For early stone and masonry buildings the load bearing, solid walls of the building also presented the appearance or façade of the building.

The style and the structural system were joined.

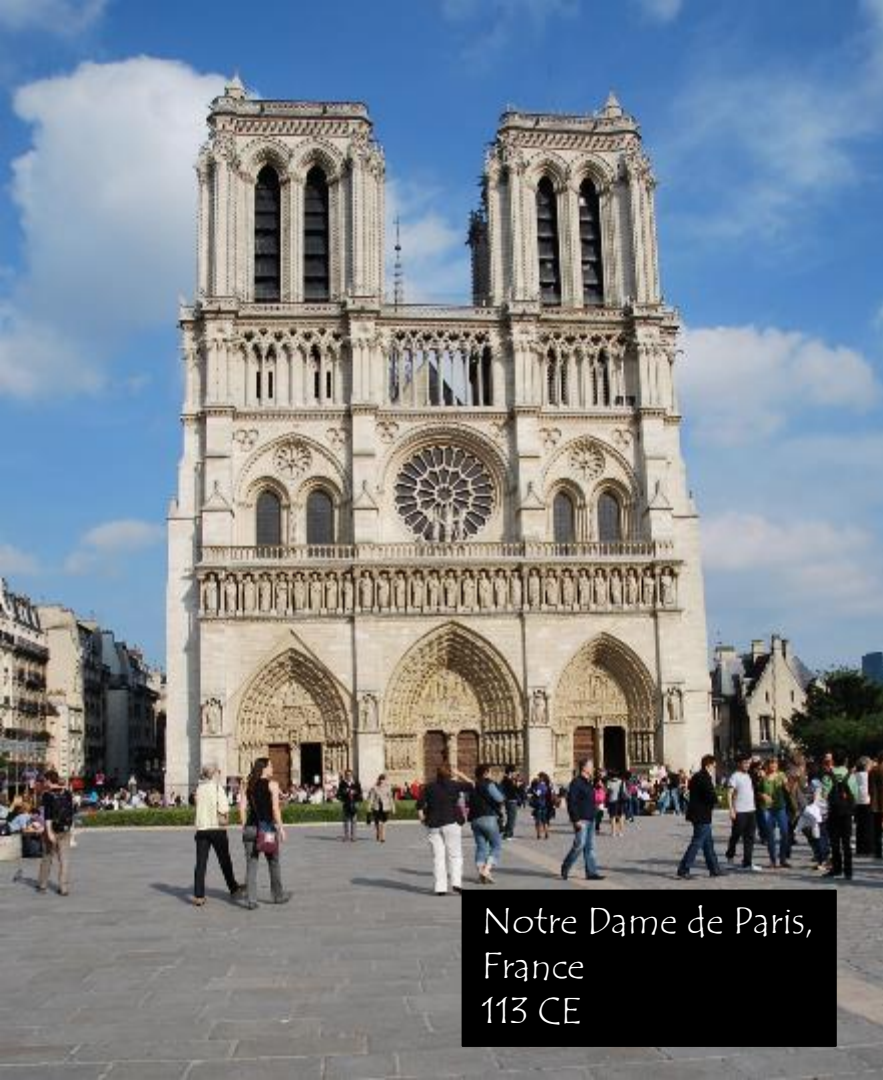

Notre Dame de Paris,
France
113 CE



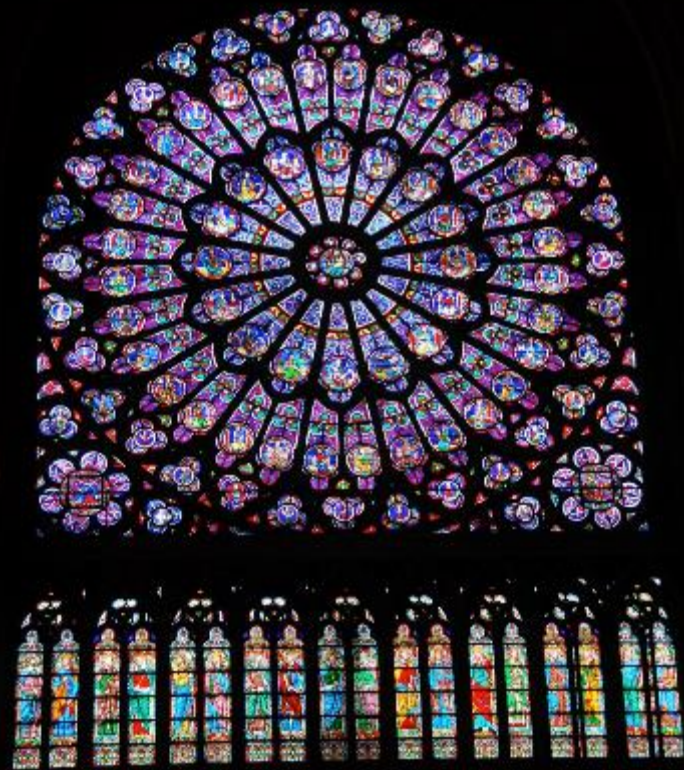



Bibliothèque Sainte-Geneviève
Paris, France
Henri Labrouste
1835-1851





Monadnock Building (north half)
Chicago, Illinois
Burnham and Root
1891

The invention of the **skeleton steel frame** at the end of the 1800s separated the roles of the structure and enclosure system.

The enclosure system took on the role of façade and had much more freedom of expression as it did not have to also support the loads of the building.

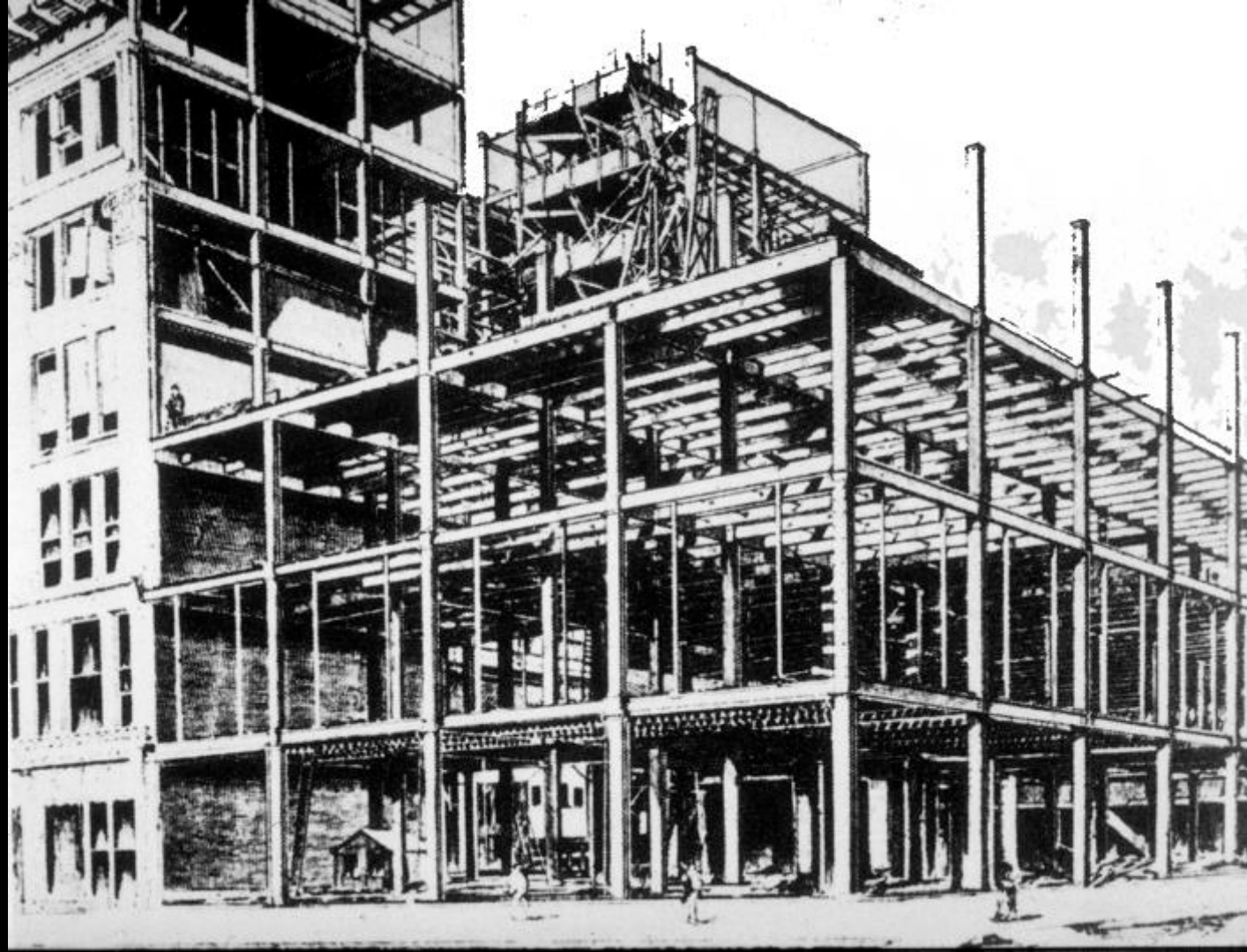



Reliance Building
Chicago, Illinois
Burnham, Root and Atwood
1895
First real skyscraper

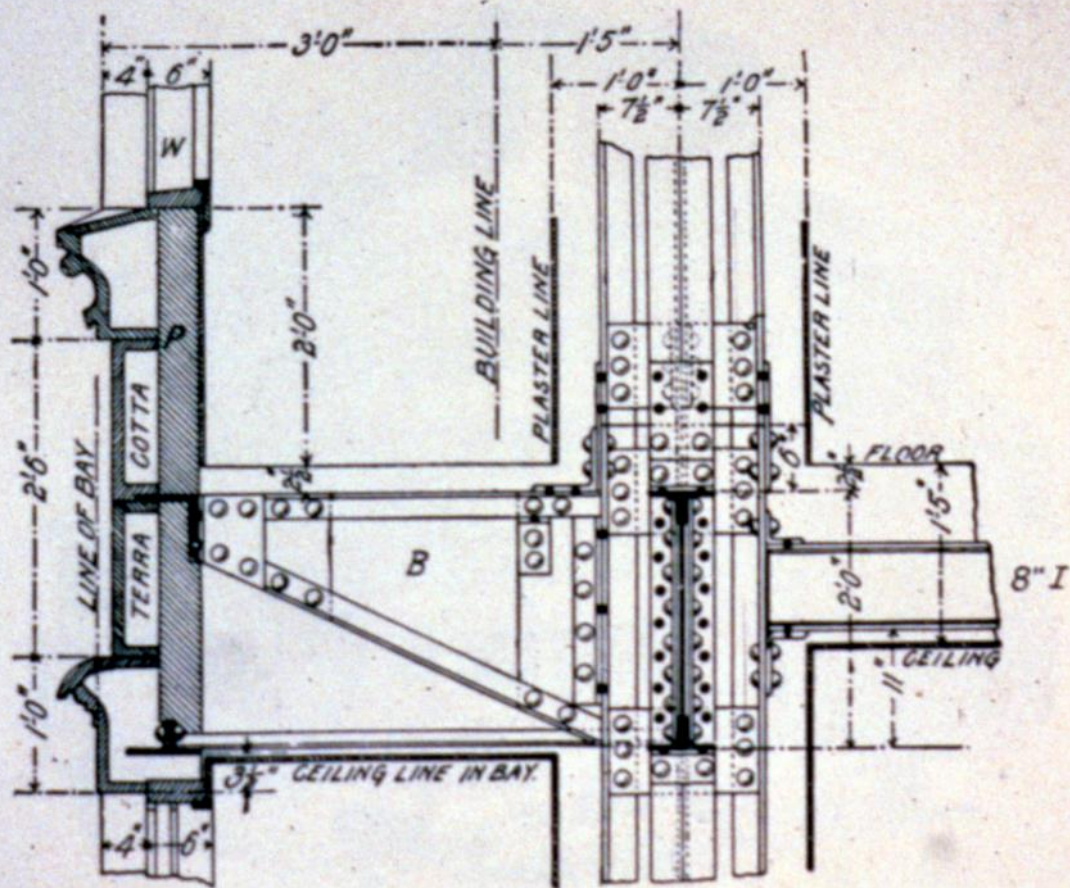

27 Atwood and Burnham, Reliance Building,
Chicago, 1890/94-95. Cross section of window bay.

Enclosure systems for Early Skyscrapers





Farnsworth House
Ludwig Mies van der Rohe
Plano, Illinois
1951



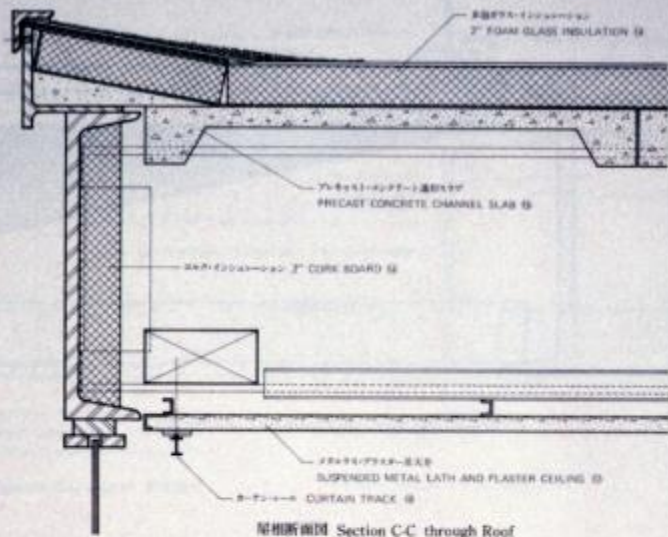

屋根断面図 Section C-C through Roof

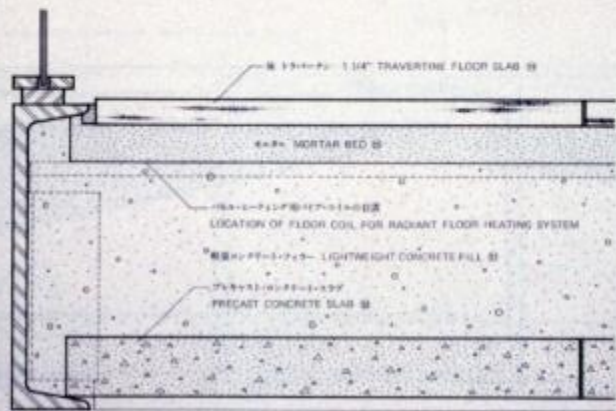

FLOOR DRAIN #34 ④

床断面図 Section C-C through Floor

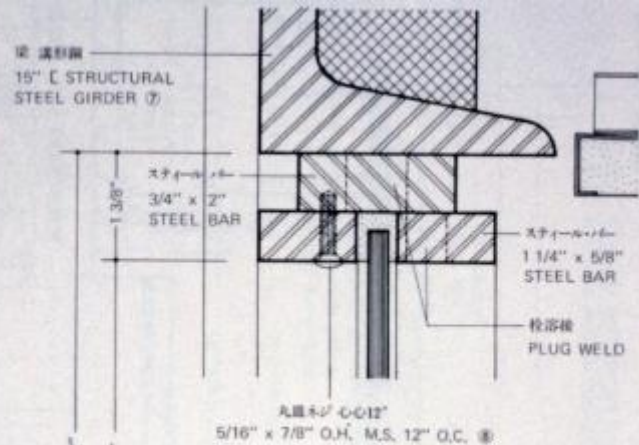

断面図 Section 109

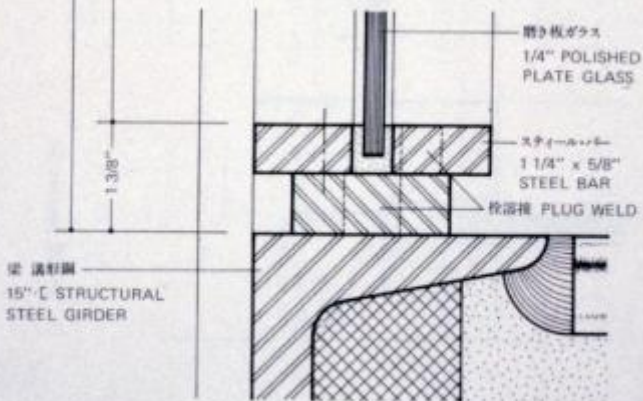

断面図 Section 110





Mies van der Rohe
Lakeshore Drive Apartments, Chicago







Tall Buildings and Curtainwall:

In the 1950s a new curtainwall enclosure system was developed based on a modular system of aluminum components that allowed large expanses of glazing.



Lever House, NYC

Different approaches to the construction of the enclosures for tall vs mid-rise vs low-rise *commercial* buildings

Tall = curtain wall

Mid-rise = less use of aluminum curtain wall and more composite layered systems with insulation

Low-rise = composite layered systems with more insulation requirements

Low-rise (mostly residential)

- Load bearing framed walls
- Insulation contained between the studs
- Glazed openings punched in the wall

Exterior cladding is a “veneer” that keeps out the weather but does not support the floors and roof

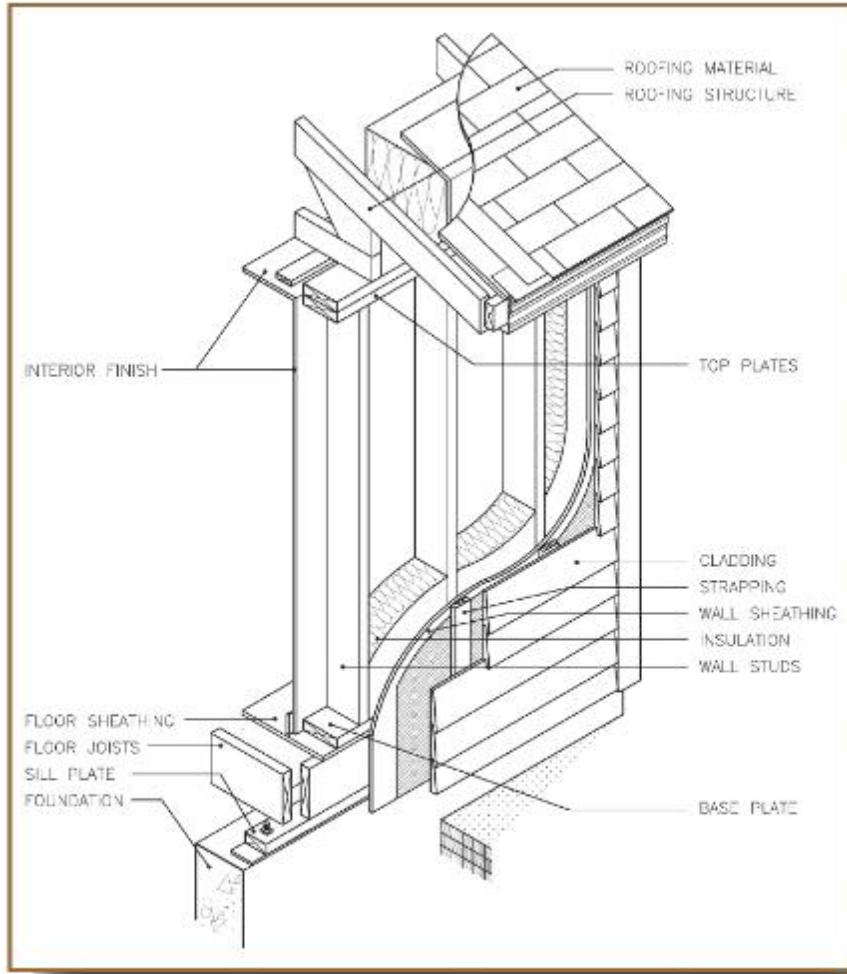
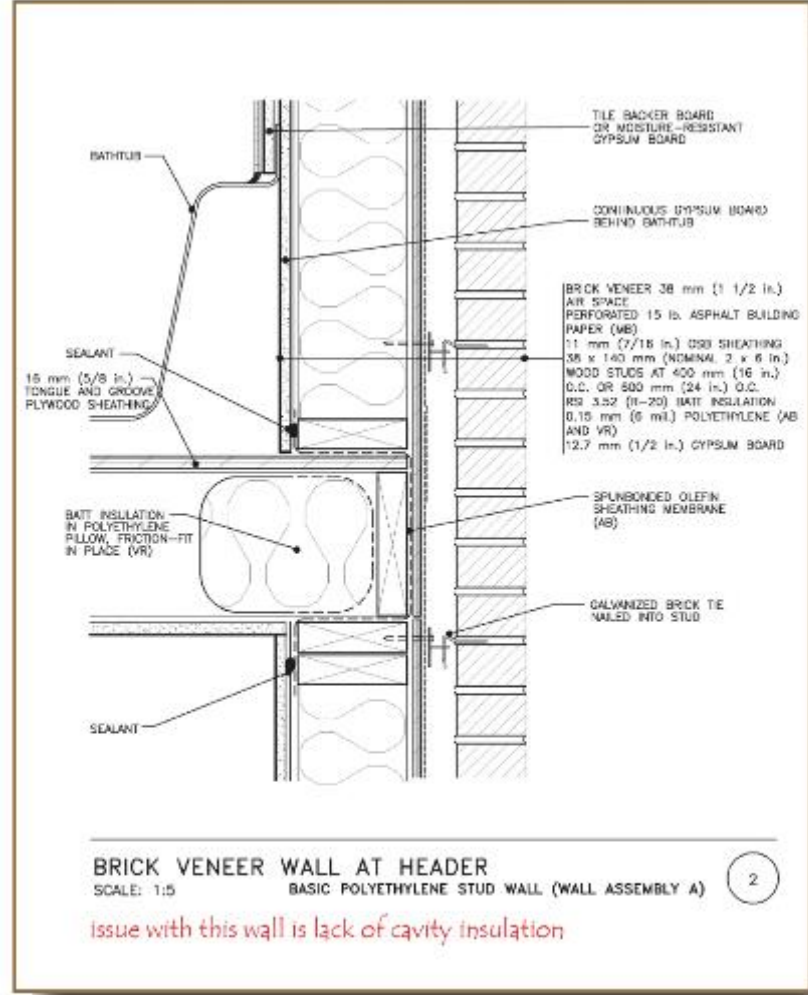

Figure 2.6: Components of a wood frame structure



Detail 2: Brick Veneer Wall at Header

Rain Screen:

In the 1960s an improved wall system was developed that placed an air space behind the outermost layer of the envelope system.

This equalized the pressure on either side of this "veneer" and prevented rain from penetrating to the interior part of the wall.



For **column and beam** type structures (non load bearing walls) it doesn't matter if the material is steel, concrete or heavy timber, the structure gets erected first, then the curtain wall/window wall is installed.







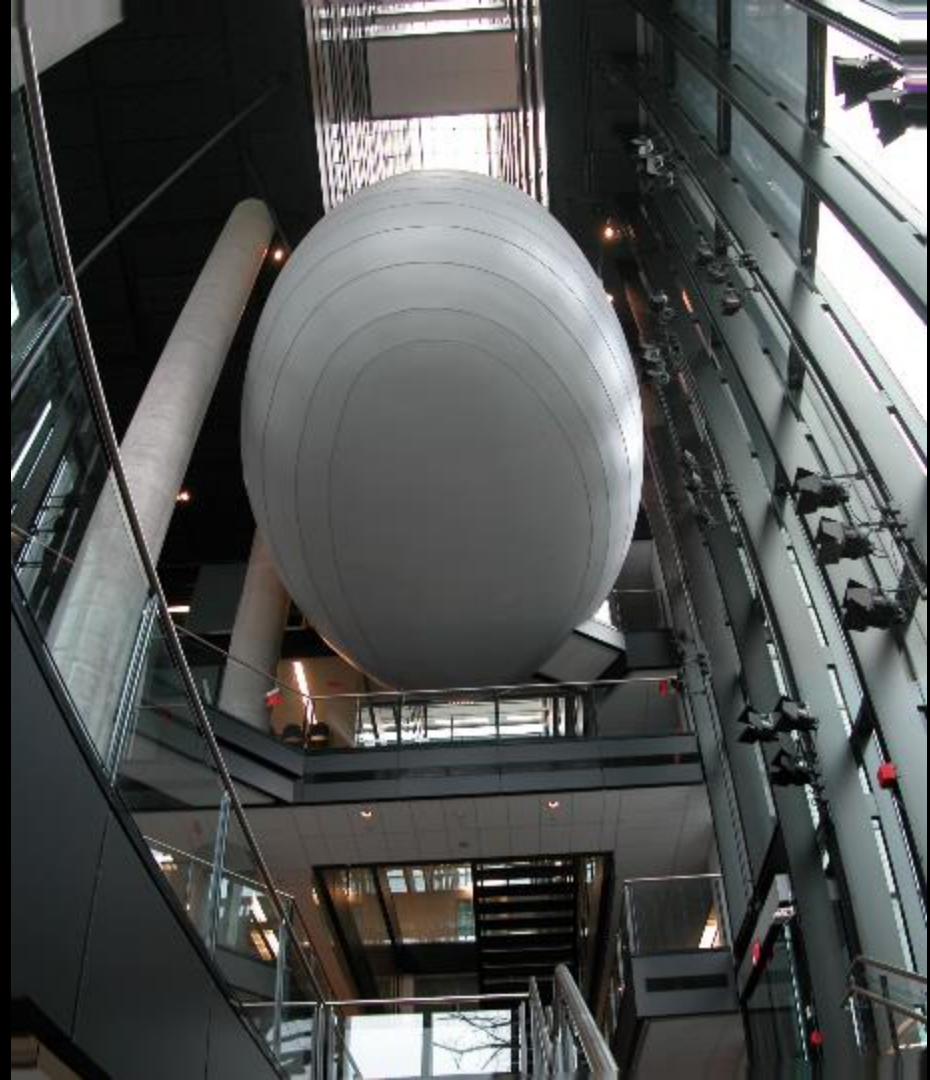













The curtain wall connects to the slab edge NOT the columns



Residential Tower
Melbourne, Australia









Swiss Re (The Gherkini)
London, England
Foster and Partners
2004







CCTV Tower
Beijing, China
OMA/Rem Koolhaas
2013









Pearl River Tower
Guangzhou, China
SOM
2013















20 Fenchurch Street
Aka The Walkie Talkie Building
London, England
Rafael Vinoly Architects
2014









CNOOC Headquarters
Beijing, China
Kohn Pederson Fox Architects





Typical curtain wall systems for commercial buildings were always sealed – no operable windows

Due to interest in sustainability, now looking for ways to include access to fresh air into the envelope design, while maintaining safety from falling.







北京同仁医院

康新堂大药房

2013年12月4日
中国经济论坛
圆满成功

十时中心







Bahn Tower
Berlin, Germany
Murphy Jahn
2000











Window Wall:

This type of enclosure for high rise buildings does not use an expansive grid of aluminum frames.

Typically has horizontal bands of windows supported by bands of precast concrete, stone, masonry or metal cladding panels.

In **window wall** construction the infill opaque wall sits (bears) on the edge of the concrete floor slab

It extends to the underside of the next floor, with a small space to allow for slab edge deflections.

Brick Veneer
Air Space
Insulation
Air Bloc 21 or O6
Concrete Masonry Unit
Furring
Gypsum Board

Blueskin® AG
Thru-Wall Flashing
Sheet

Air Bloc 21

Blueskin® SA or AG
Transition Sheet

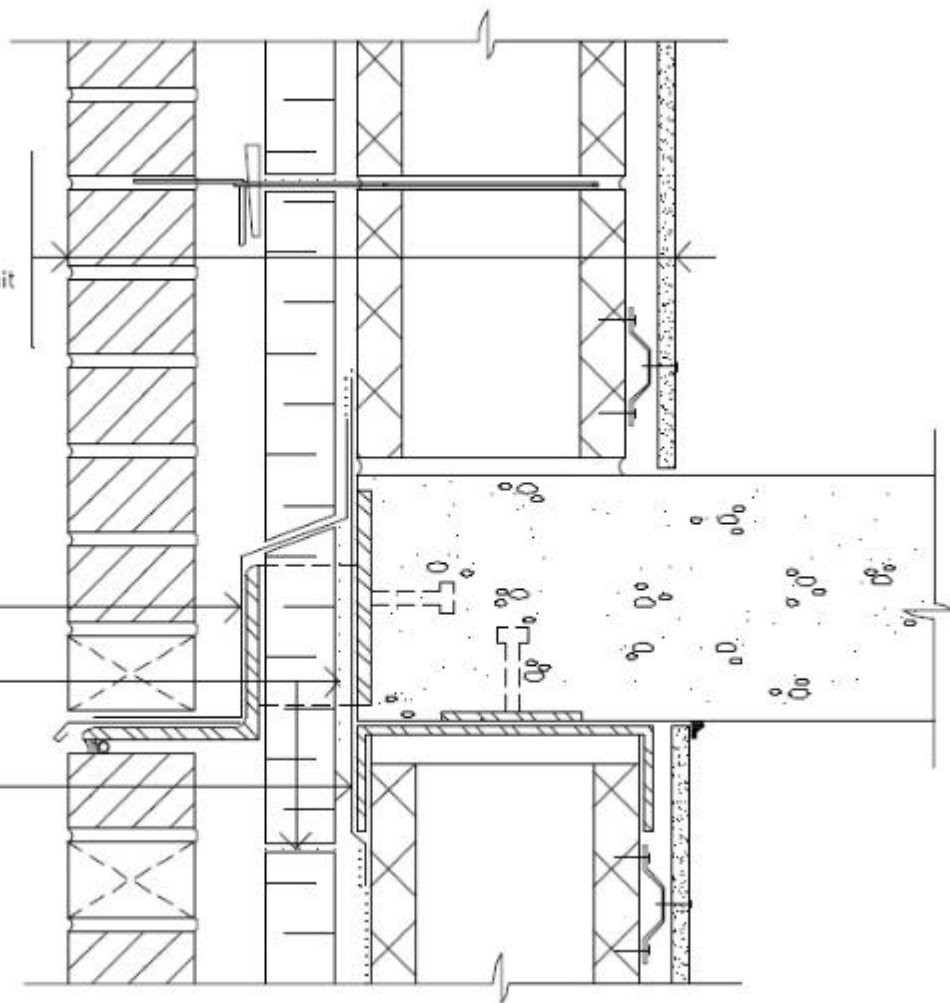

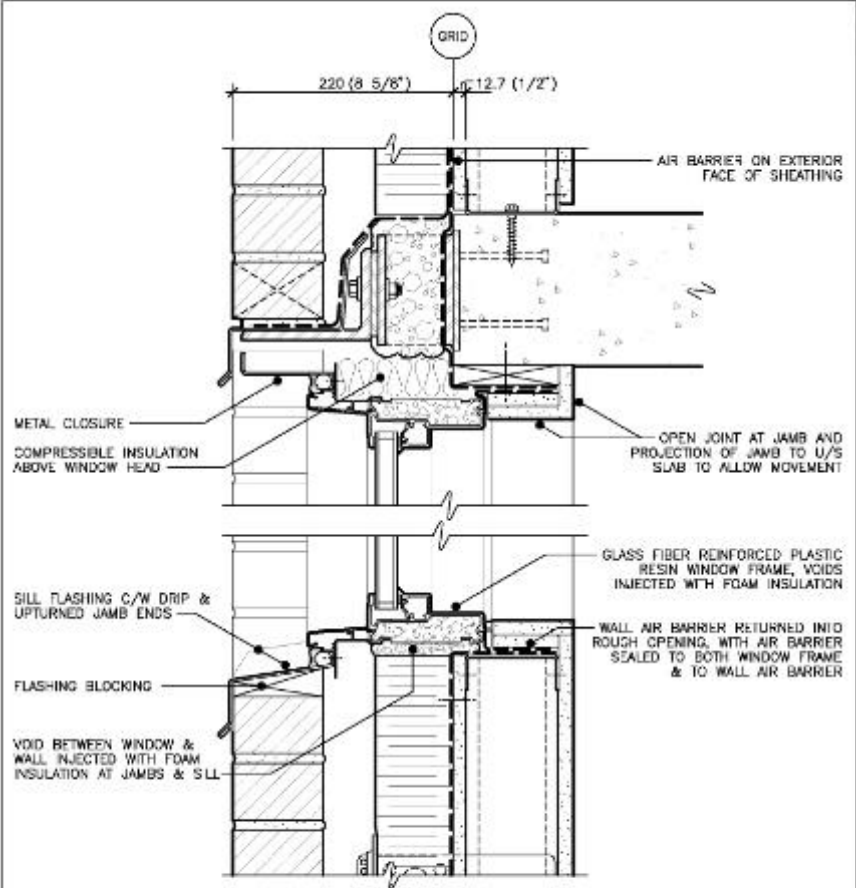

4 WINDOW AT U/S SLAB DETAIL

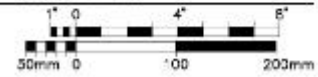

Which to use?

CURTAIN WALL

- Regular geometry
- Large expanses of glazing
- Limited use of opaque elements
- Typical aluminum frame systems spanning one to two floors height
- Lower insulation values achieved

WINDOW WALL

- Any kind of geometry
- Limited glazing
- Glazing often as punched or strip windows
- Large opaque portions
- Better insulation levels required

Thermal Bridge

A VERY BAD place in the building envelope that allows HEAT to ESCAPE

No insulation layer preventing heat flow

Usually happens at concrete slab edges





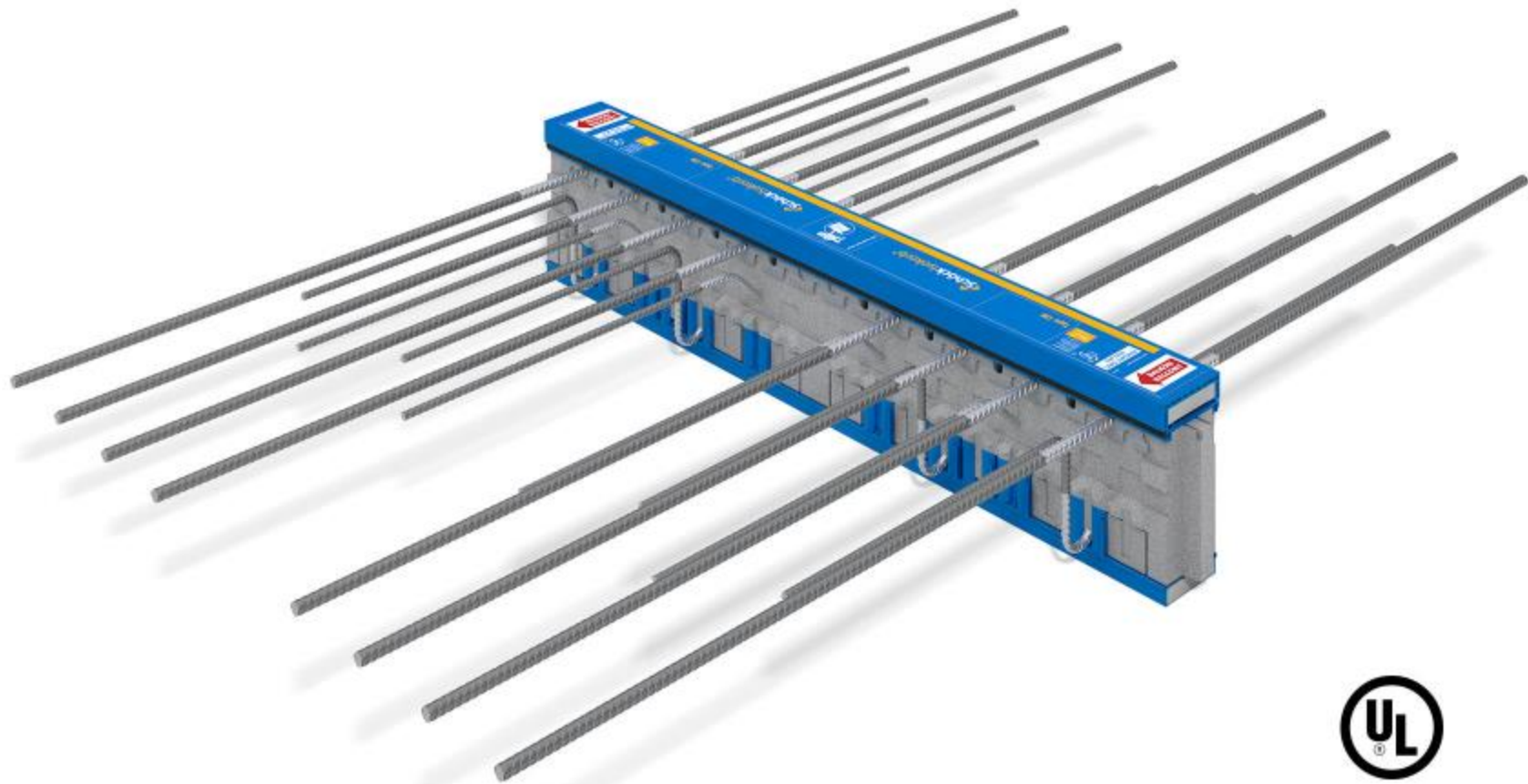













56 Leonard Street
New York City
Herzog & deMeuron





Vancouver House
Vancouver, BC
Bjarke Ingles Group











Toronto Metropolitan University
Student Learning Centre
Toronto, Ontario
Snohetta
2015









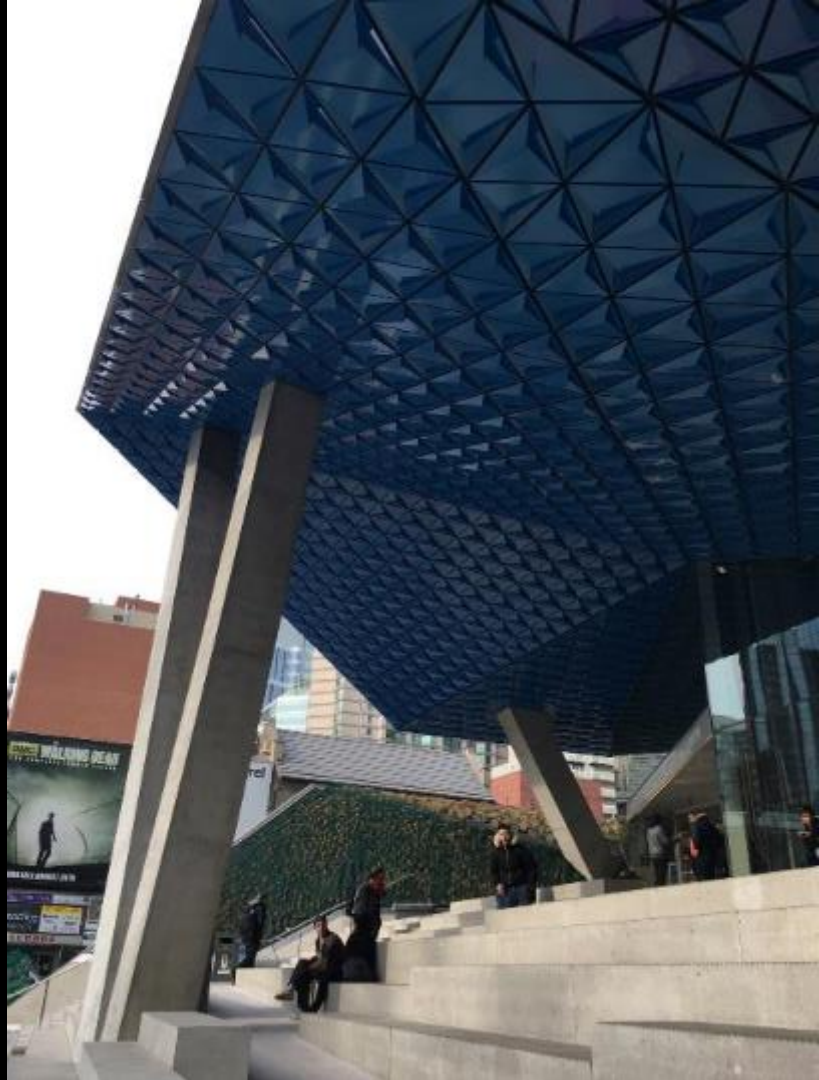





Office Building
Potsdamer Platz
Berlin, Germany
Richard Rogers

























Berlin

Die Mauer ist ein Symbol für
eine Stadt mit zwei Gesichtern
und ist

die Stadt

im Jahr 1961

nach der Mauer gebaut ist die Stadt
einmal wieder ein Stück weiter
auf dem Weg

Berlin

im Jahr 1961

die Stadt

Berlin

Die Mauer ist ein Symbol für
eine Stadt mit zwei Gesichtern
und ist

die Stadt

im Jahr 1961

nach der Mauer gebaut ist die Stadt
einmal wieder ein Stück weiter
auf dem Weg

Berlin

die Stadt

Berlin

Von Friedrich Schlegel 1810
Die Stadt ist ein Stück weiter
auf dem Weg

Dutch Embassy
Berlin, Germany
OMA

reel



















Thin Metal Cladding / Veneer



Chrysler Building
NYC 1930



Frank Gehry...





Residential Building
Berlin, Germany
Zaha Hadid









Linked Hybrid
Beijing, China
Steven Holl Associates
2009









Galaxy Soho
Beijing, China
Zaha Hadid

渤海银行









北京市京畿律师事务所

链家房产

链家房产

PLAZA 8









Conrad Hotel
MAD Architects
Beijing, China











Royal Ontario Museum, Toronto
Studio Libeskind





Residence
Roger Williams University
Bristol, Rhode Island
Perkins + Will Architects









School of Architecture
Penn State University
WTW Architects



STUCKEY FAMILY
BUILDING















Shading Motivated Systems



Le Corbusier and the Brise Soliel



Veer Towers
Las Vegas, Nevada
Murphy Jahn Architects
2010

























TESCO *express*













Al Bahar Towers
Abu Dhabi, UAE
Aedas Architects
2012











Education City
Doha, Qatar

















Al Noor Butterfly Pavilion
Sharjah, UAE
3deluxe Architects
2015

















Doha Tower
Doha, Qatar
Jean Nouvel
2012





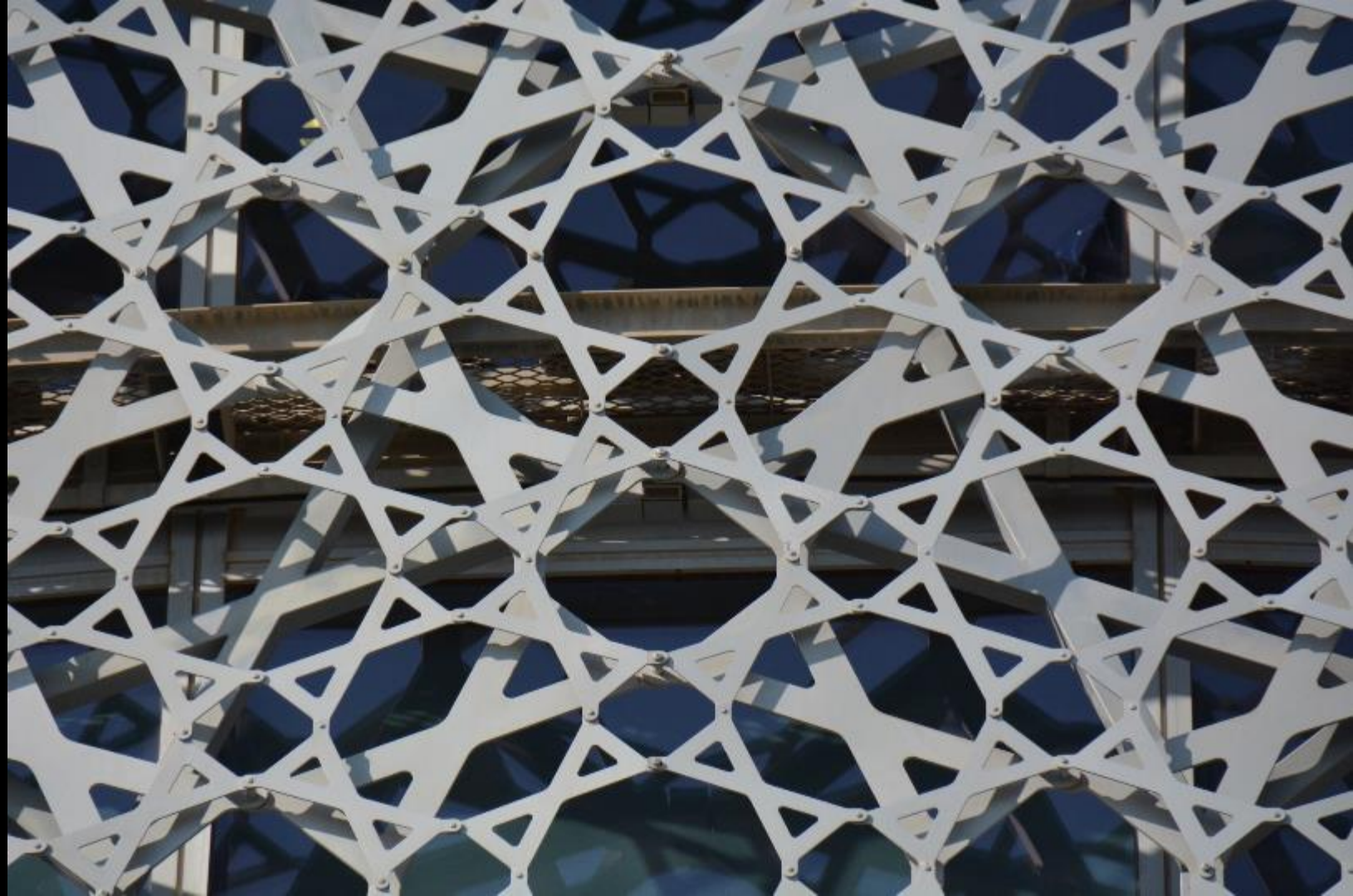













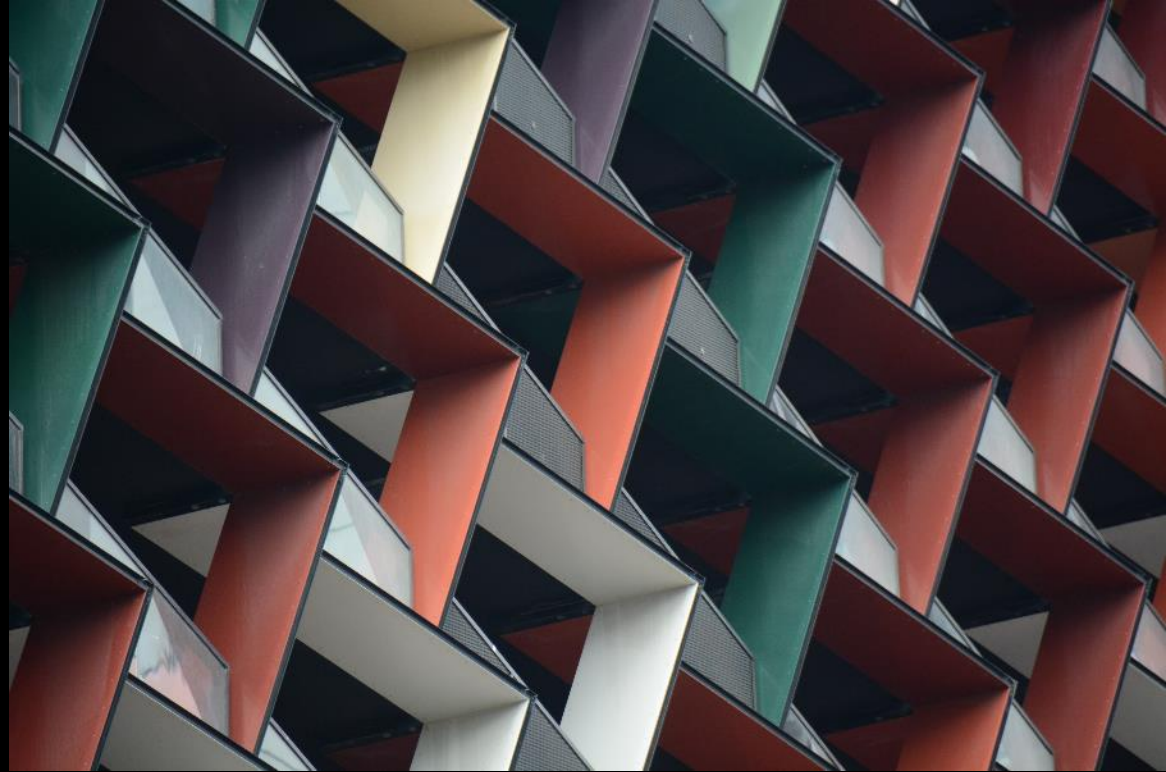



The Index
Dubai, UAE
Foster and Partners
2010





























People's Daily New Headquarters
Beijing, China
Southeast University School of Architecture
2015









永争第一

永争第一

禁止吸烟



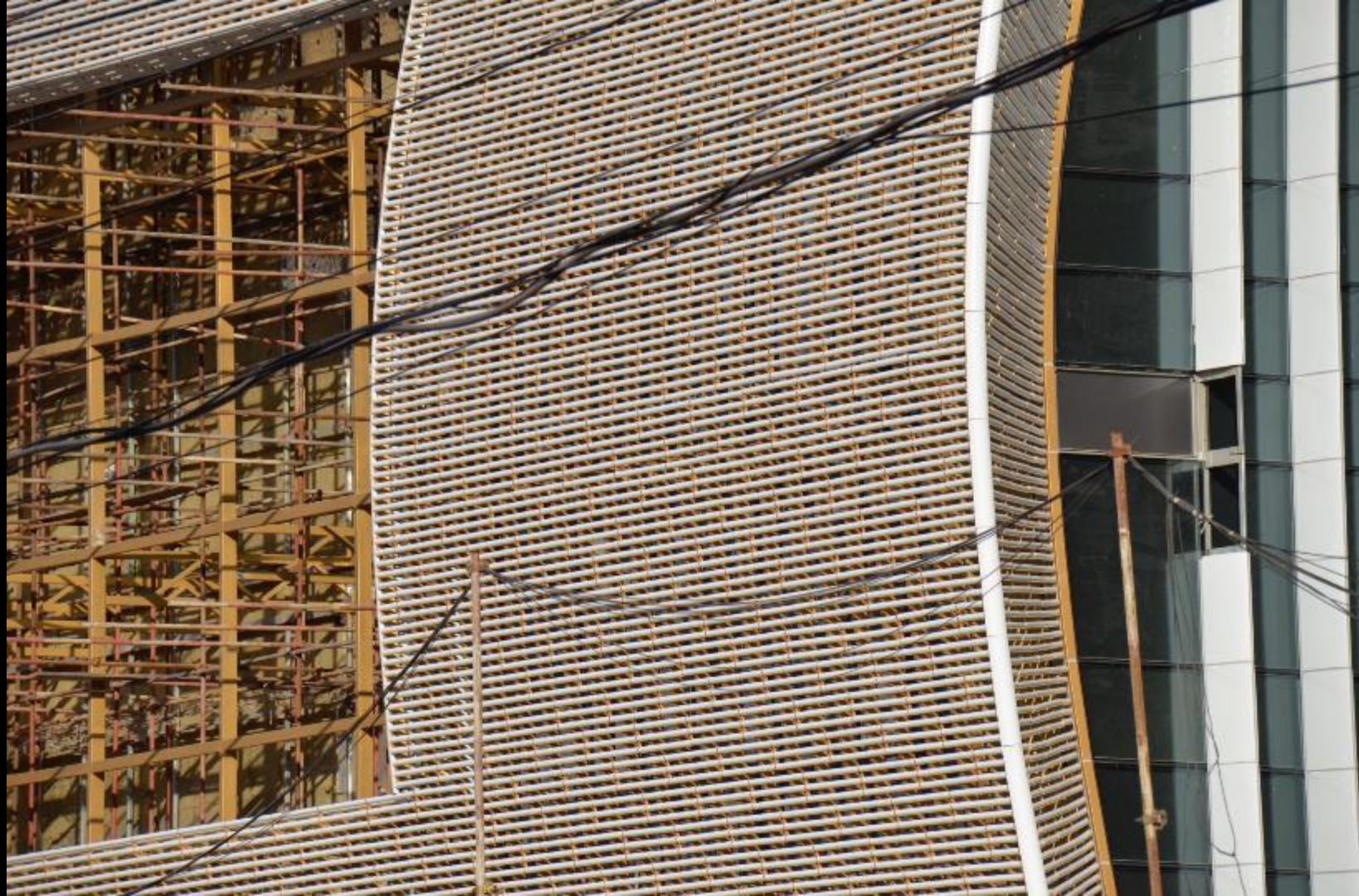







Various
Melbourne, Australia





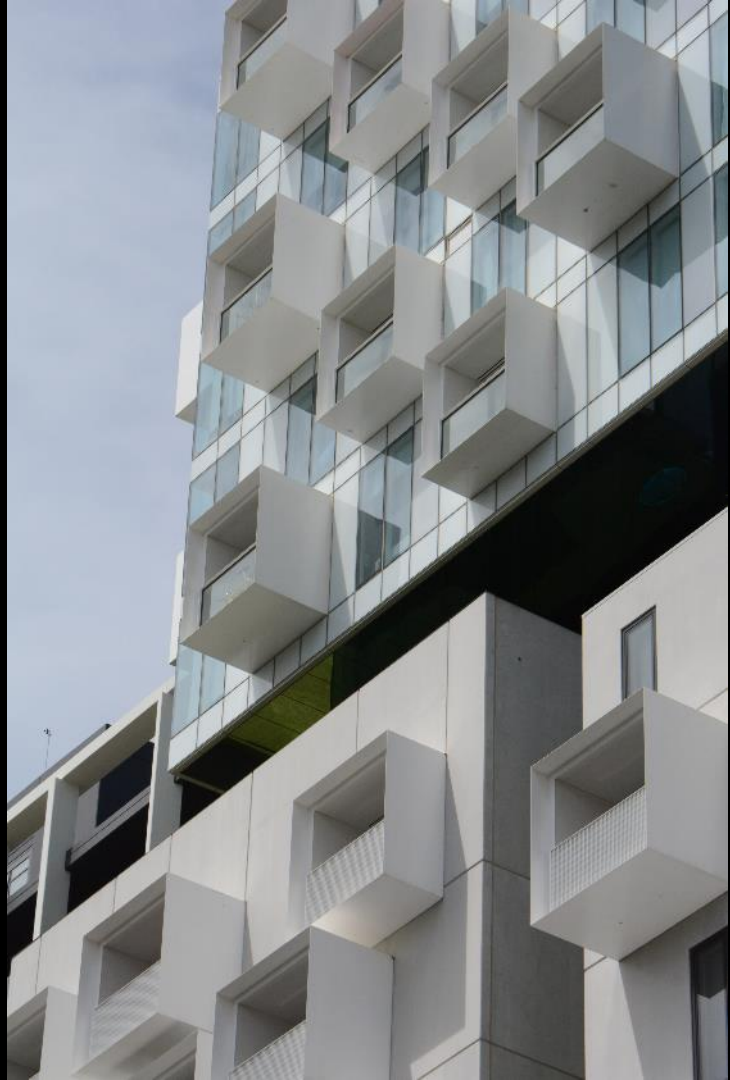





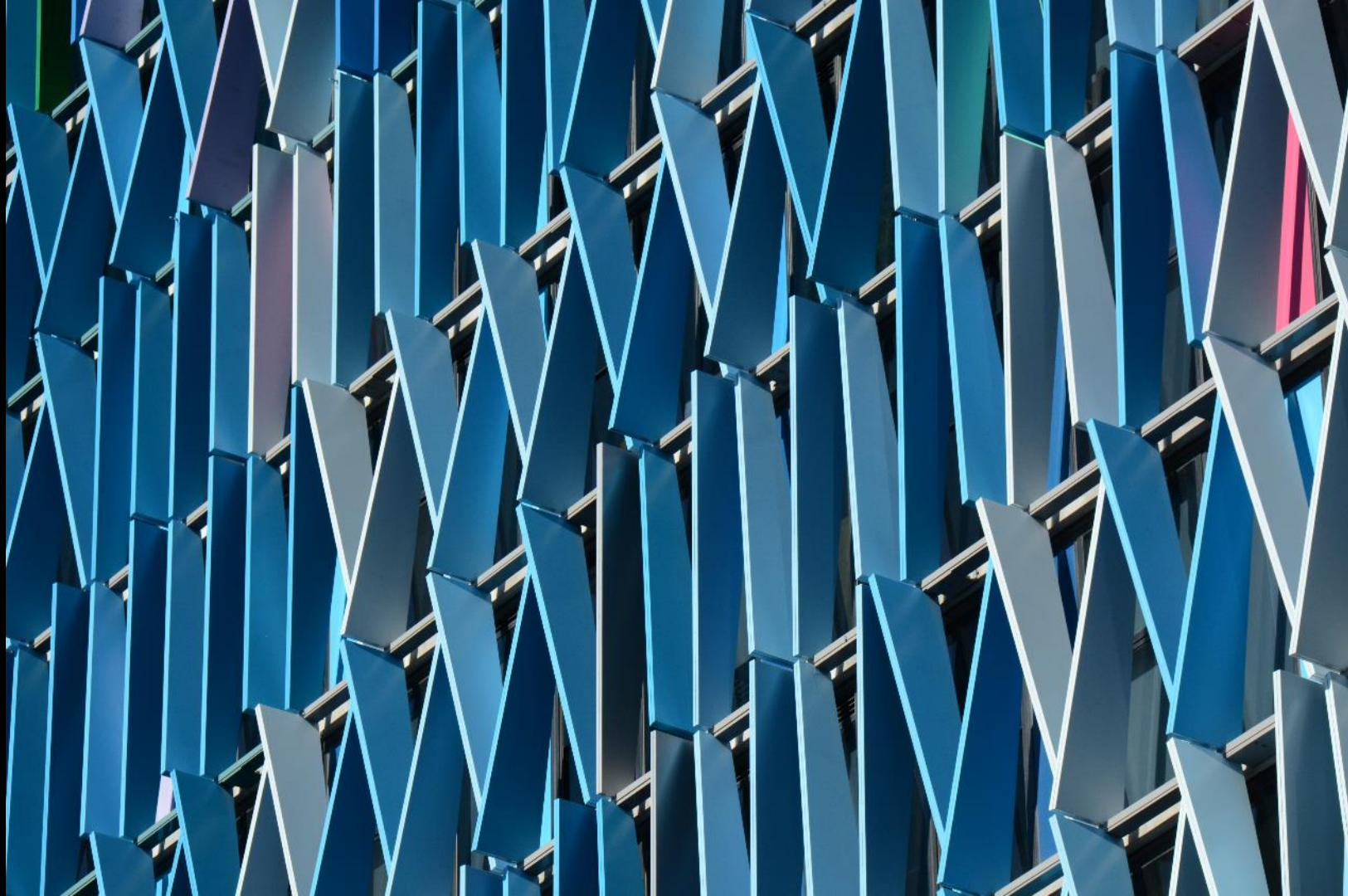



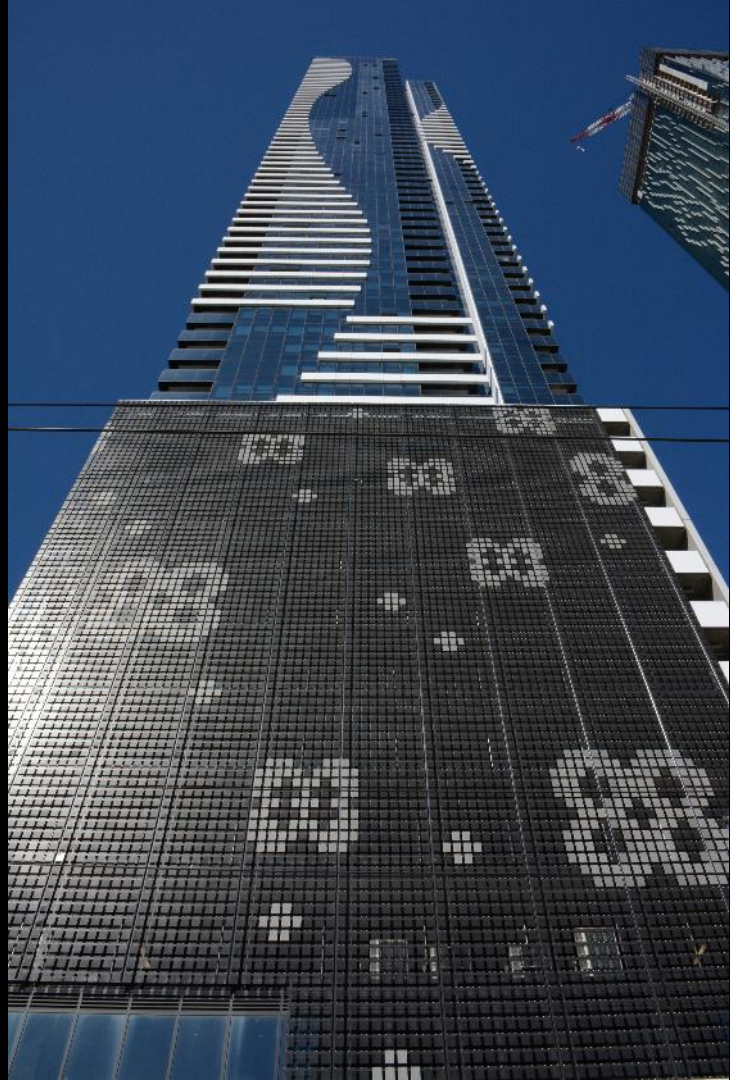
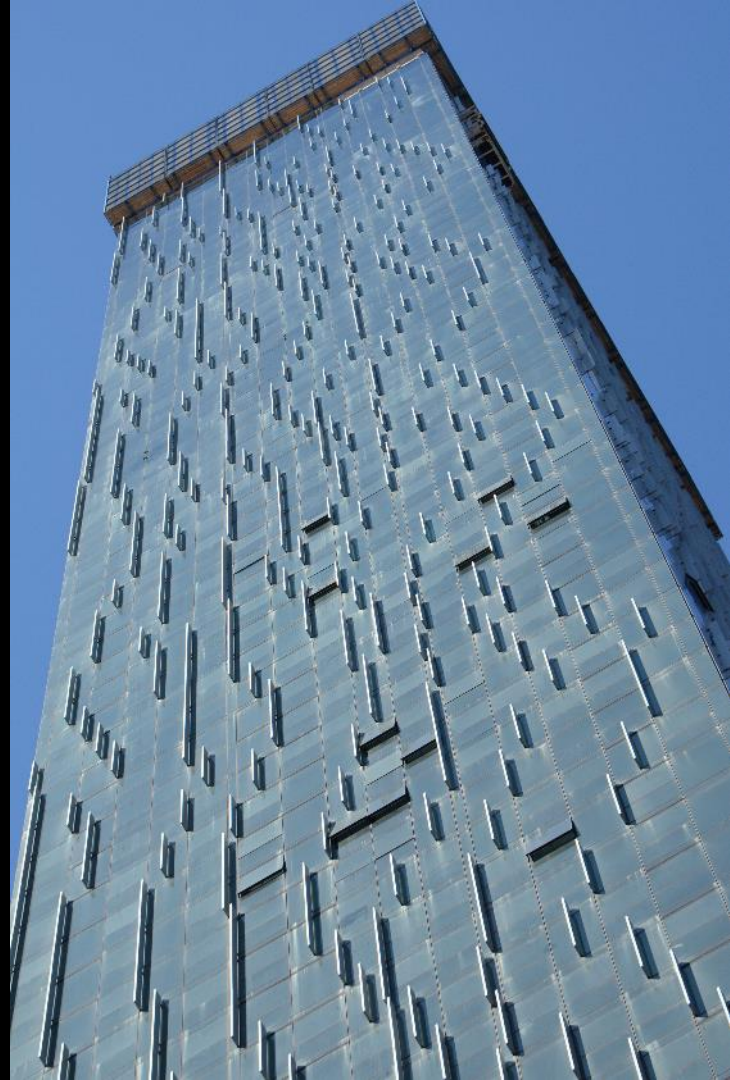

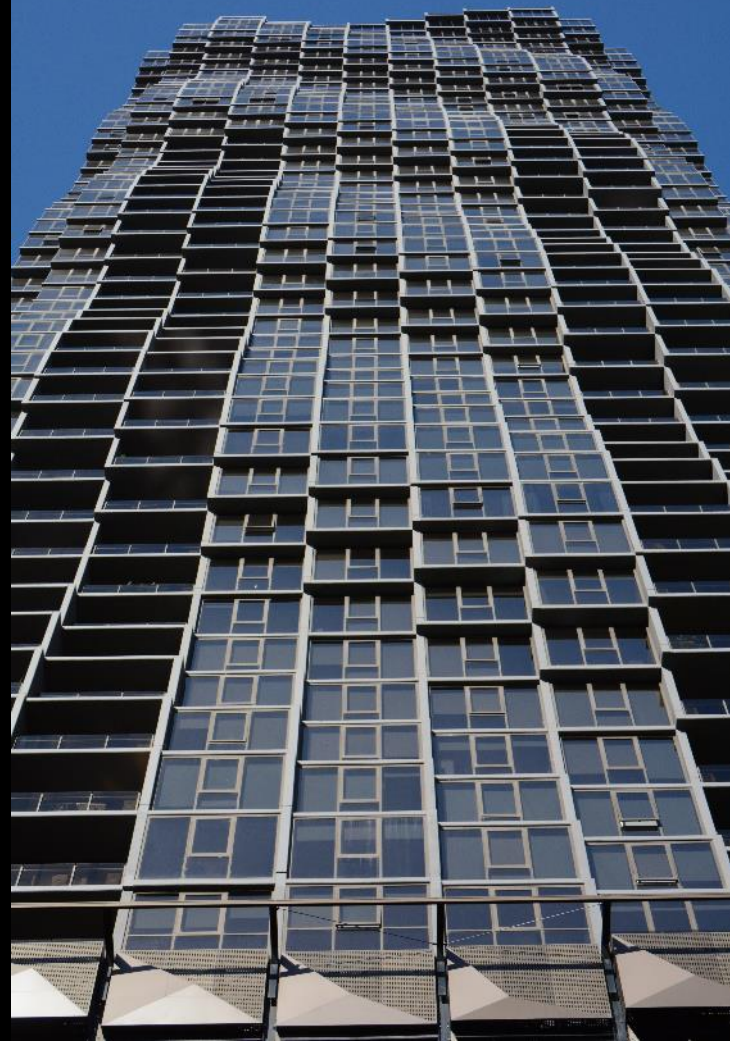

















Royal Melbourne Institute of
Technology
Accounting Building
Melbourne, Australia
Lyons Architects







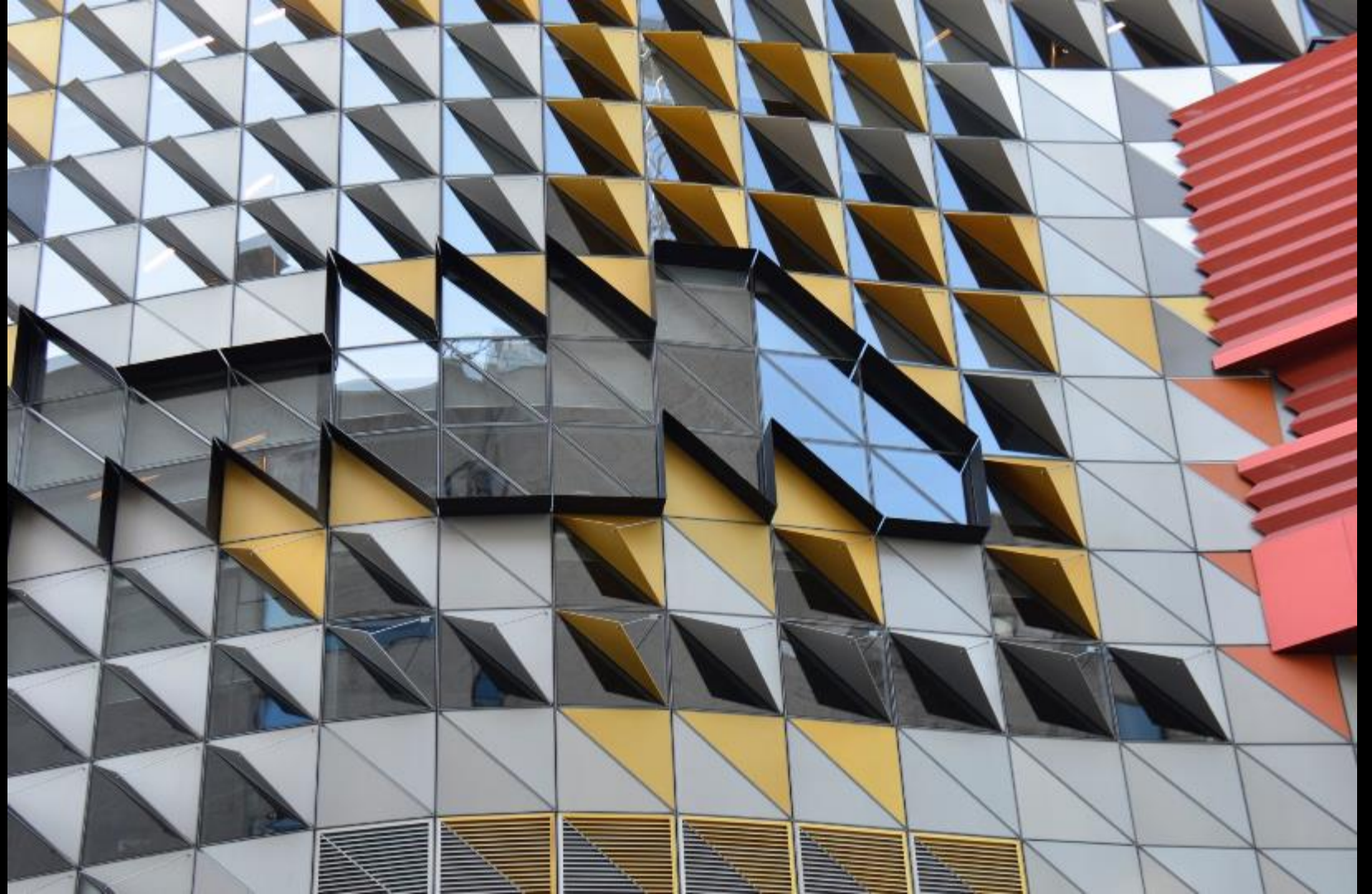

















Pixel Building
Melbourne, Australia
Studio 505



CENTRAL
Cleaning Supplies
347 7044

OATES
CLEAN

Oates

HP
50



50















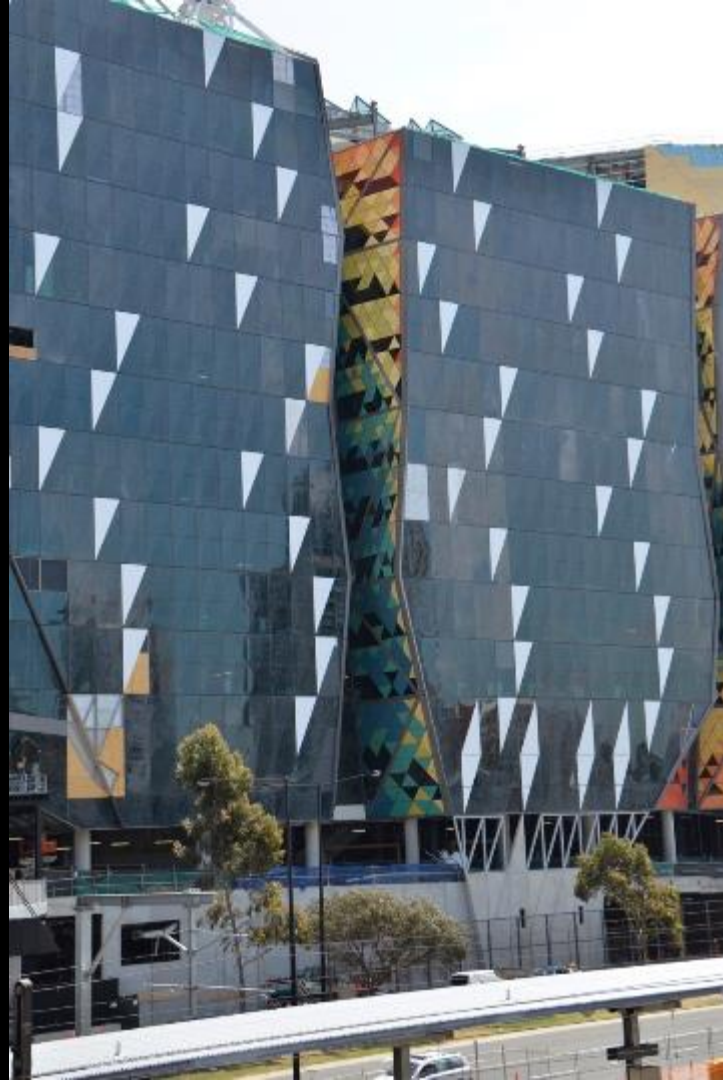

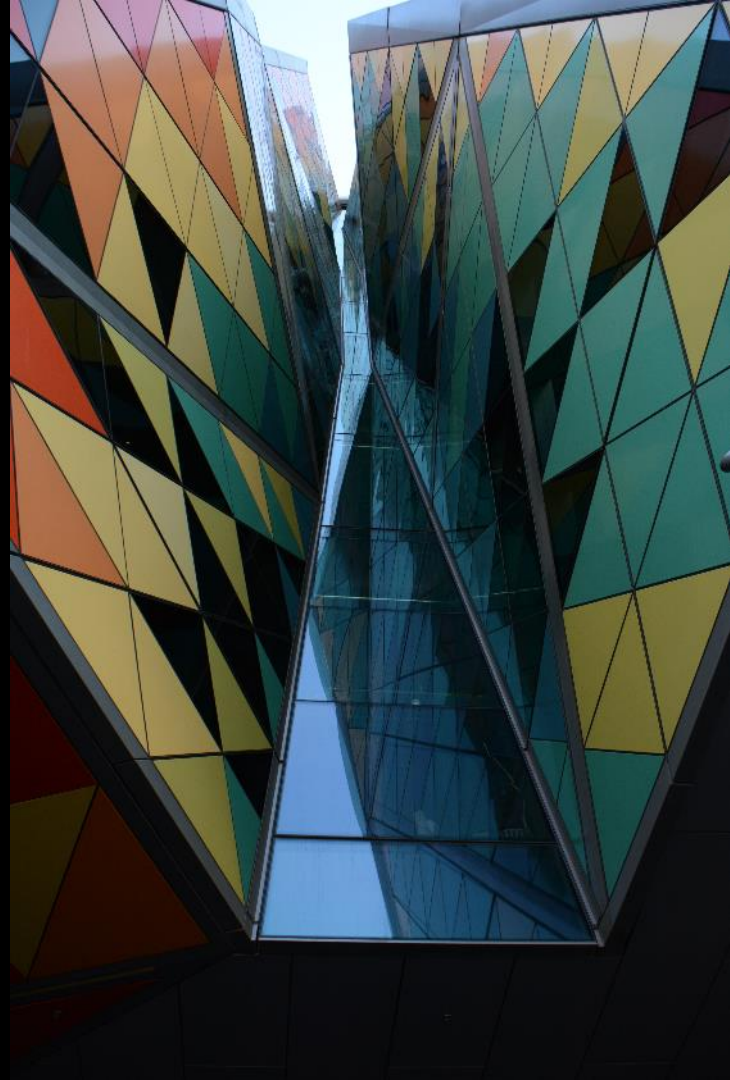
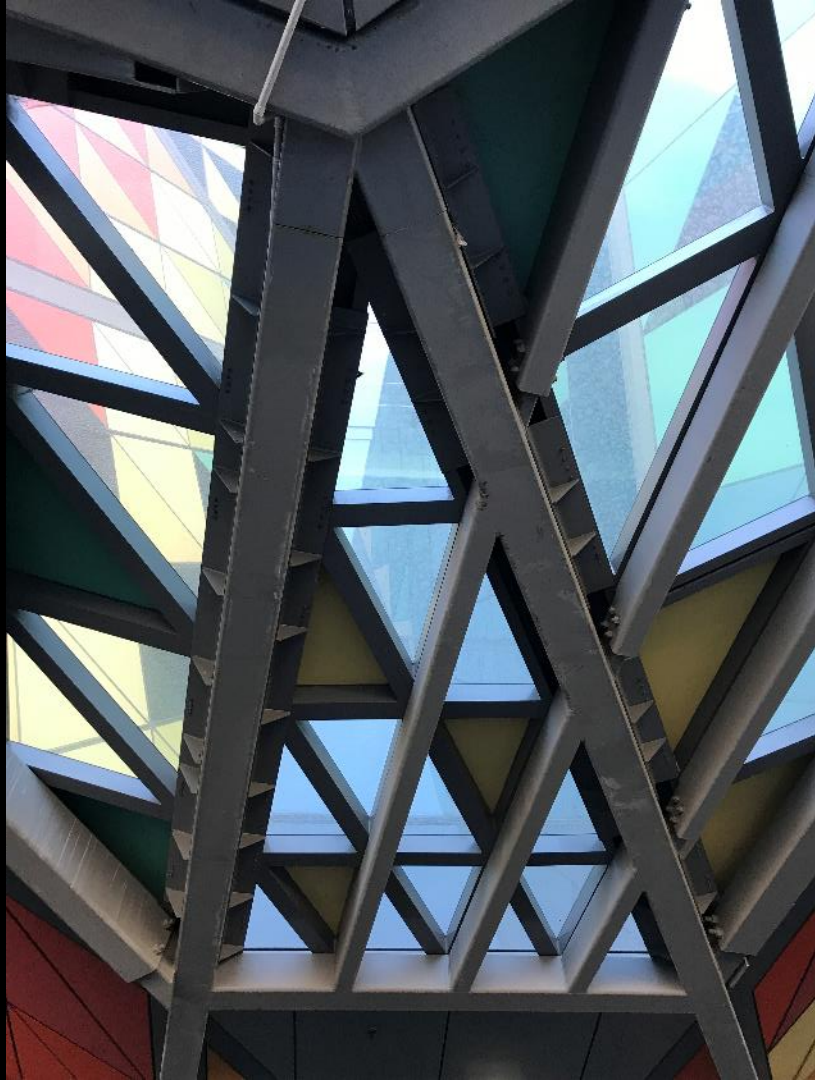



RMIT Design Hub
Melbourne, Australia
Peddle Thorp Architects

SWANSTON SQUARE
APARTMENTS

SWANSTON SQUARE

BRANDERS

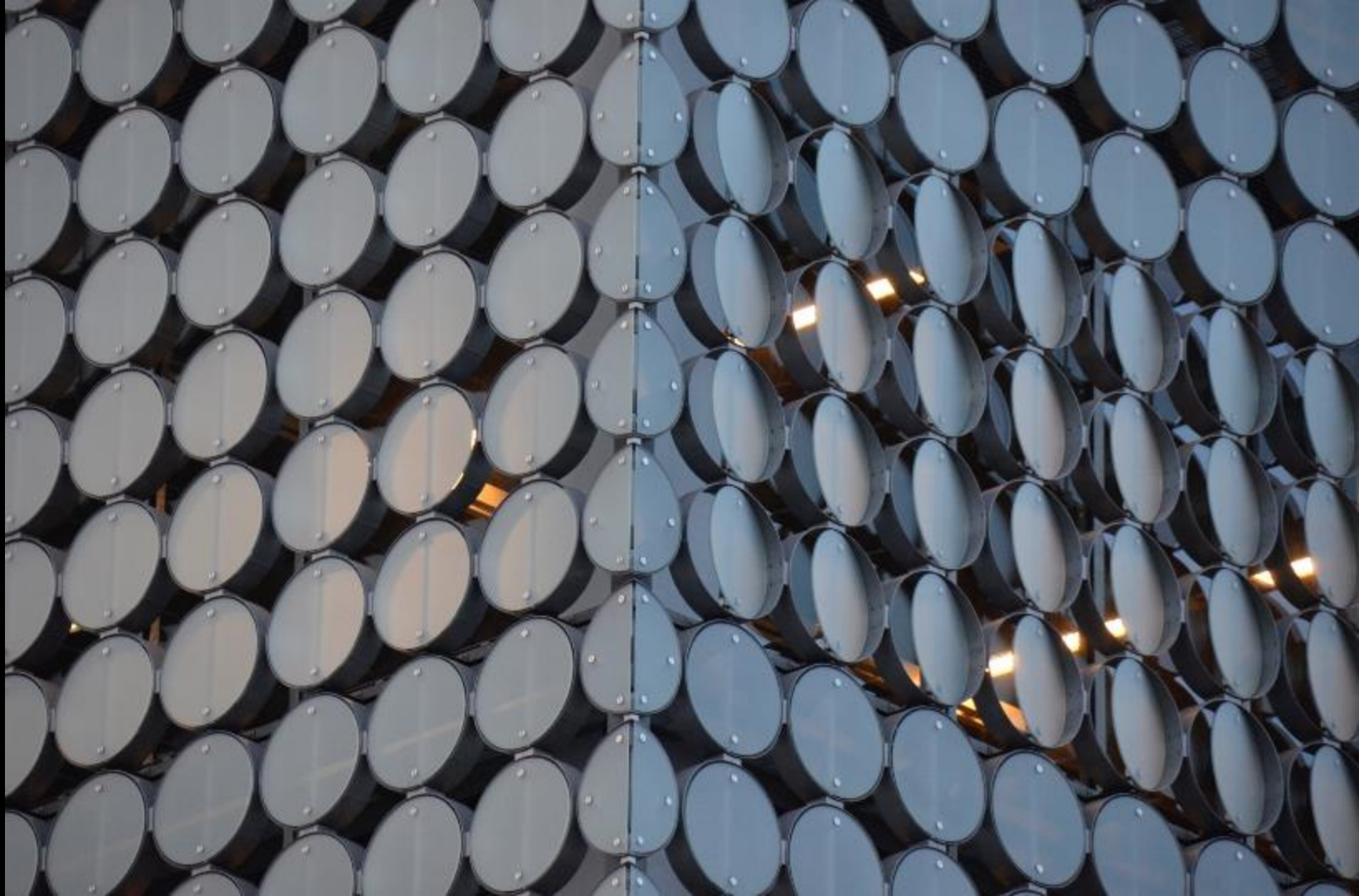



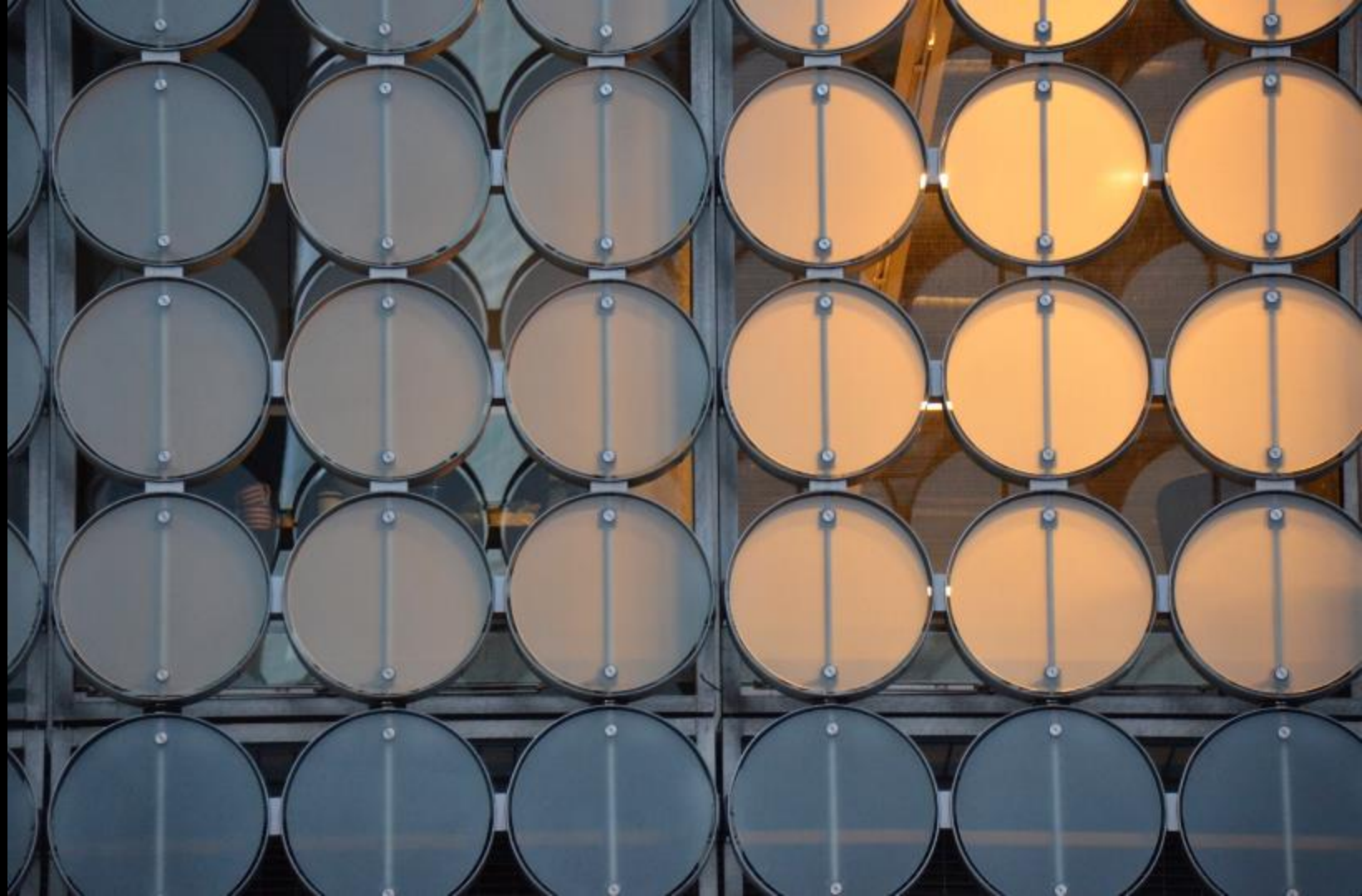





Various Projects
Brisbane, Australia









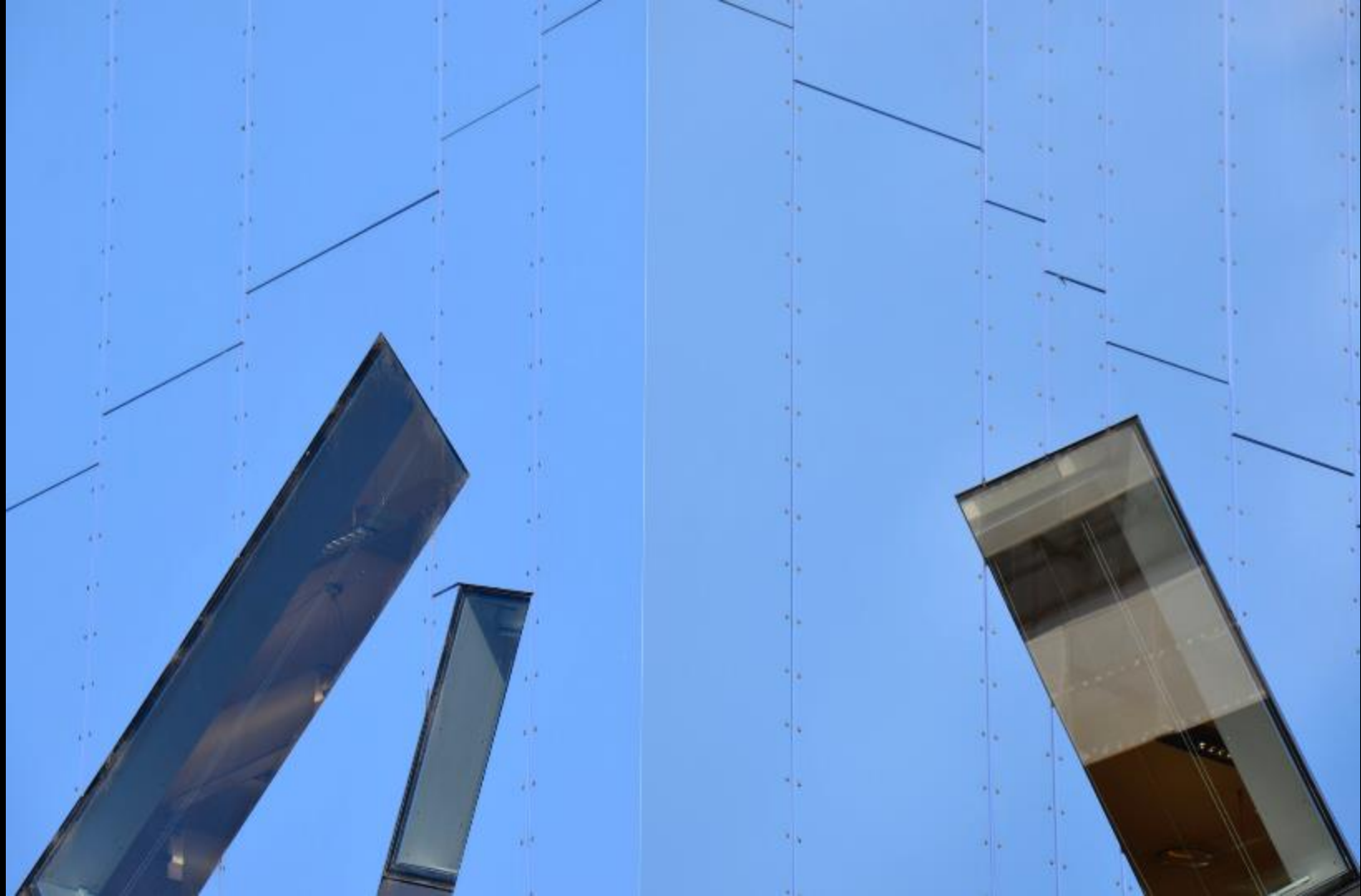

Stone Veneer Systems



Guangzhou Opera House
Guangzhou, China
Zaha Hadid Architects
2010







漢國酒餐廳























St. Giles Complex
London, England
Renzo Piano















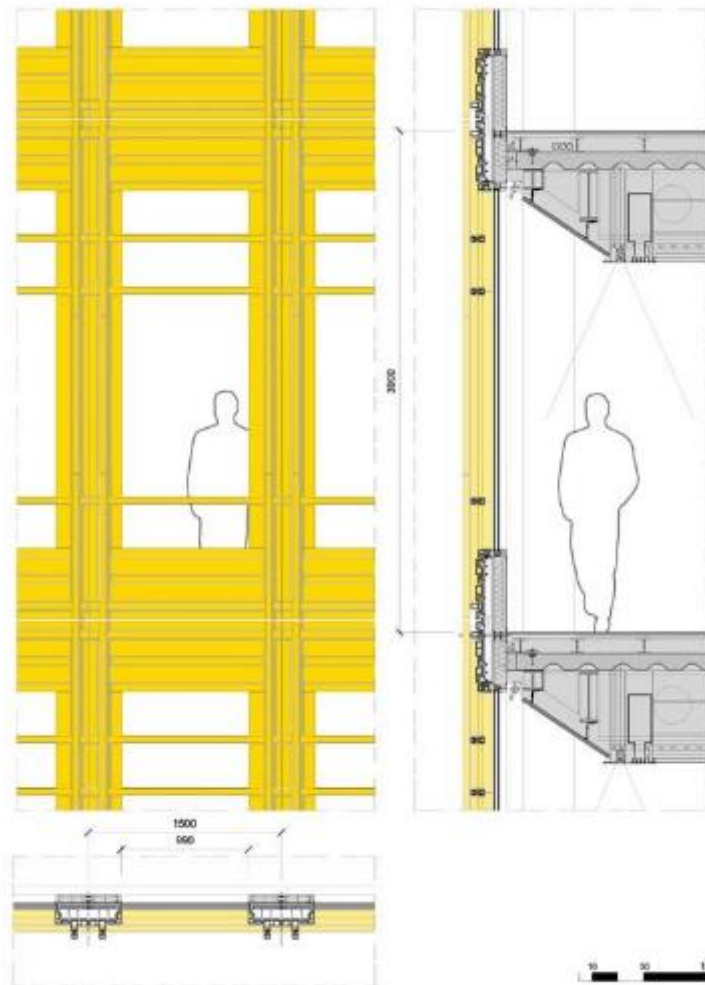

Fibre Reinforced Concrete

Fibre reinforced concrete is a type of concrete that includes fibrous substances that increase its structural strength and cohesion.

Fibre reinforced concrete has small distinct fibers that are homogeneously dispersed and oriented haphazardly.

Fibres used are steel fibers, synthetic fibres, glass fibres and natural fibres.



1 in. Crack
Opening



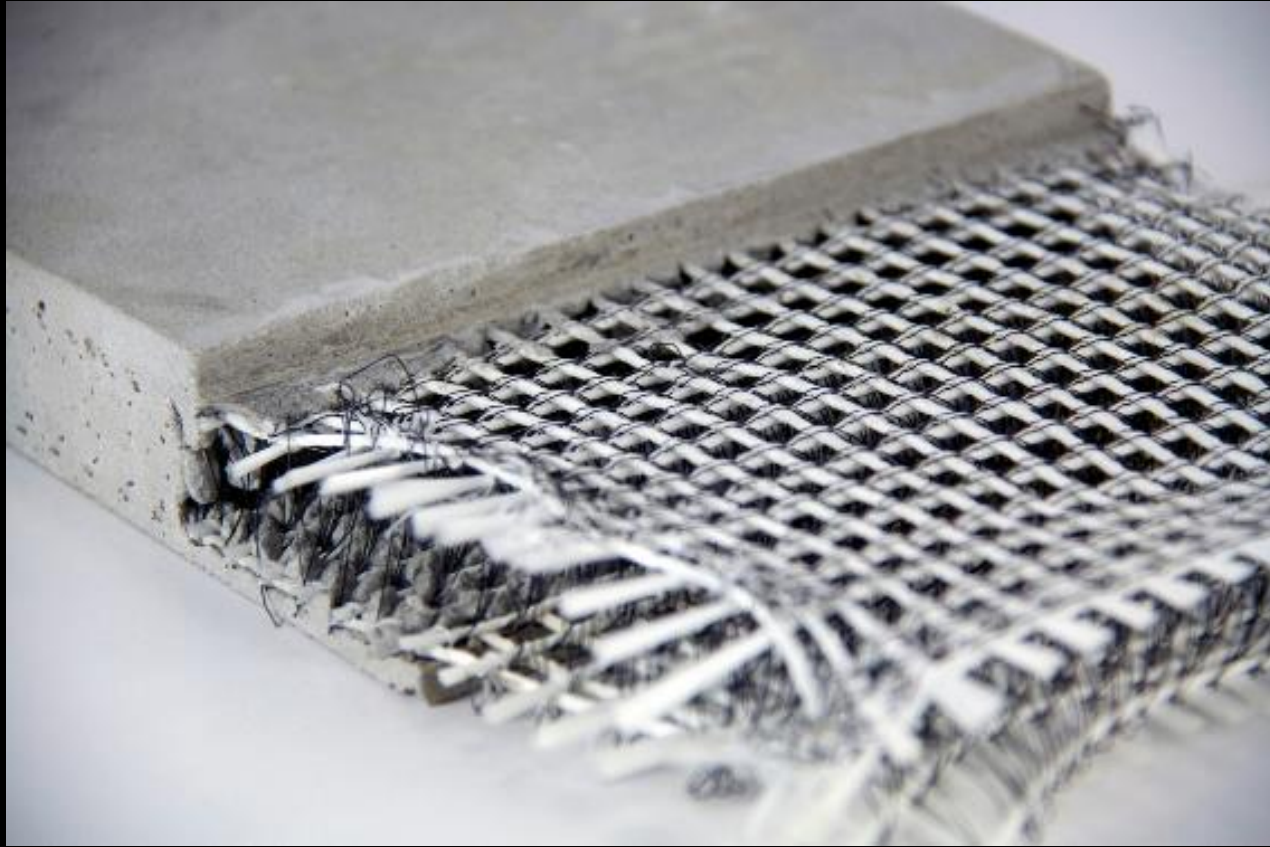



ROYAL ROSE



الروز





The FRP (fibre reinforced panels) are pretty thin, unlike precast concrete, and are often supported behind by a steel frame which is then attached to the building structure behind.



Academic Bridge Program
Education City
Doha, Qatar





Masdar Institute
Foster and Partners
Abu Dhabi, UAE
2010







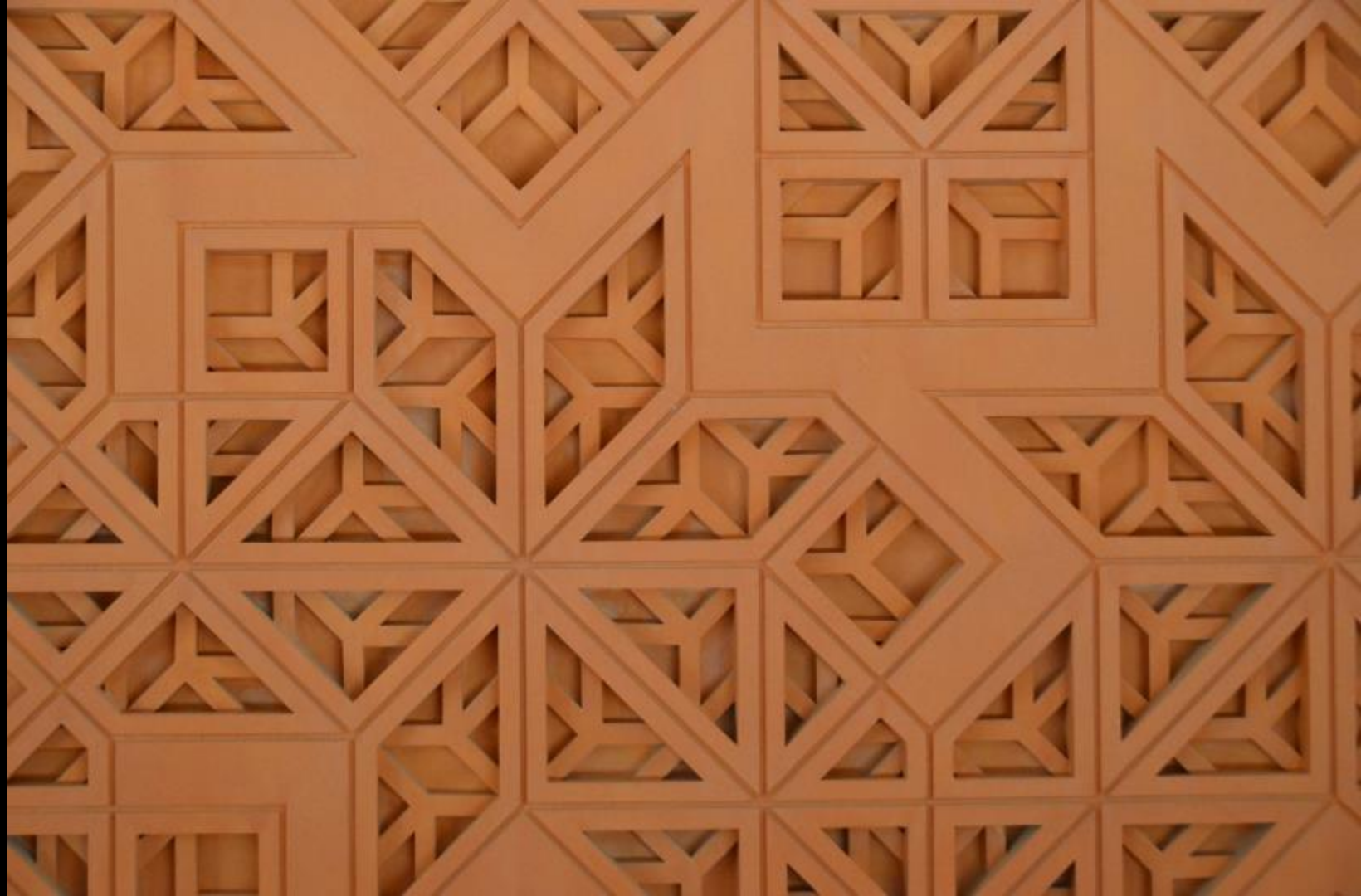



The Broad Museum
Los Angeles, California
Diller Scofidì + Renfro
2015





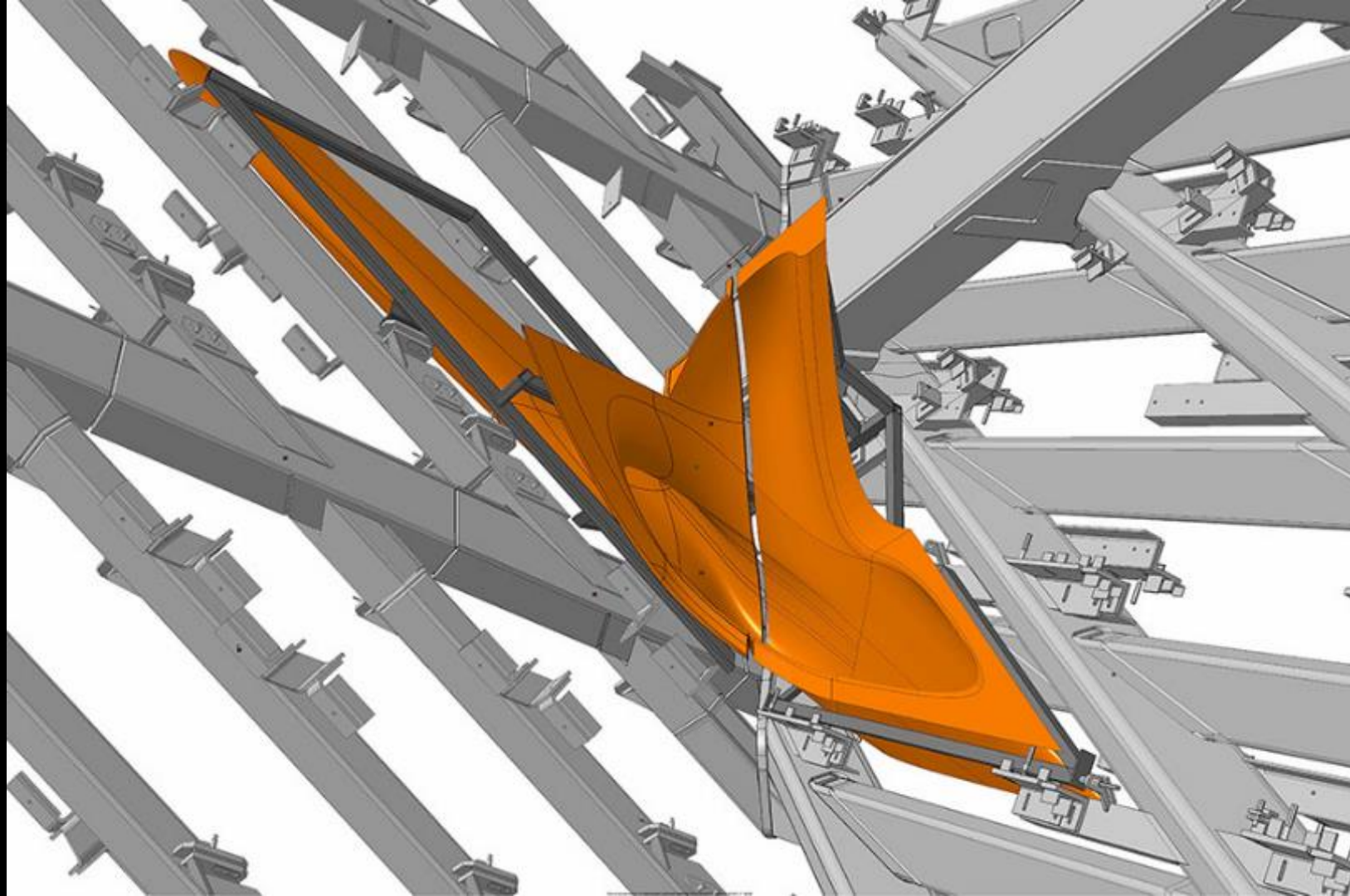



G11
NOV 2012

G11
NOV 2012
NE

G11
NOV 2012
W









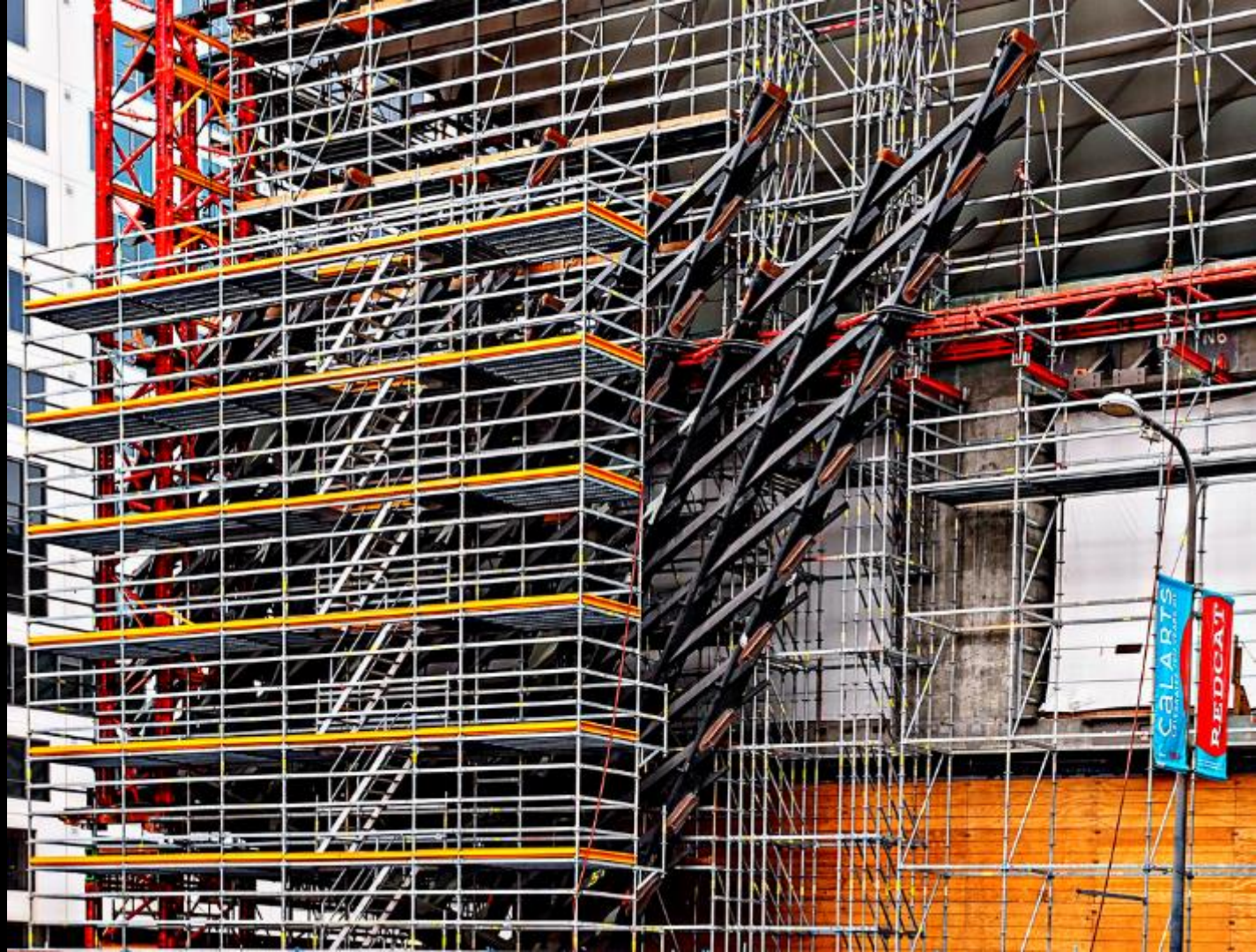



THE ROAD

TAKASHI MURAKAMI

MARK BRADFORD

CINDY SHERMAN

ROBERT THOMAS

ROY LICHENSEN

JOSEPH SEAR

CELEBRATE
REDCAT

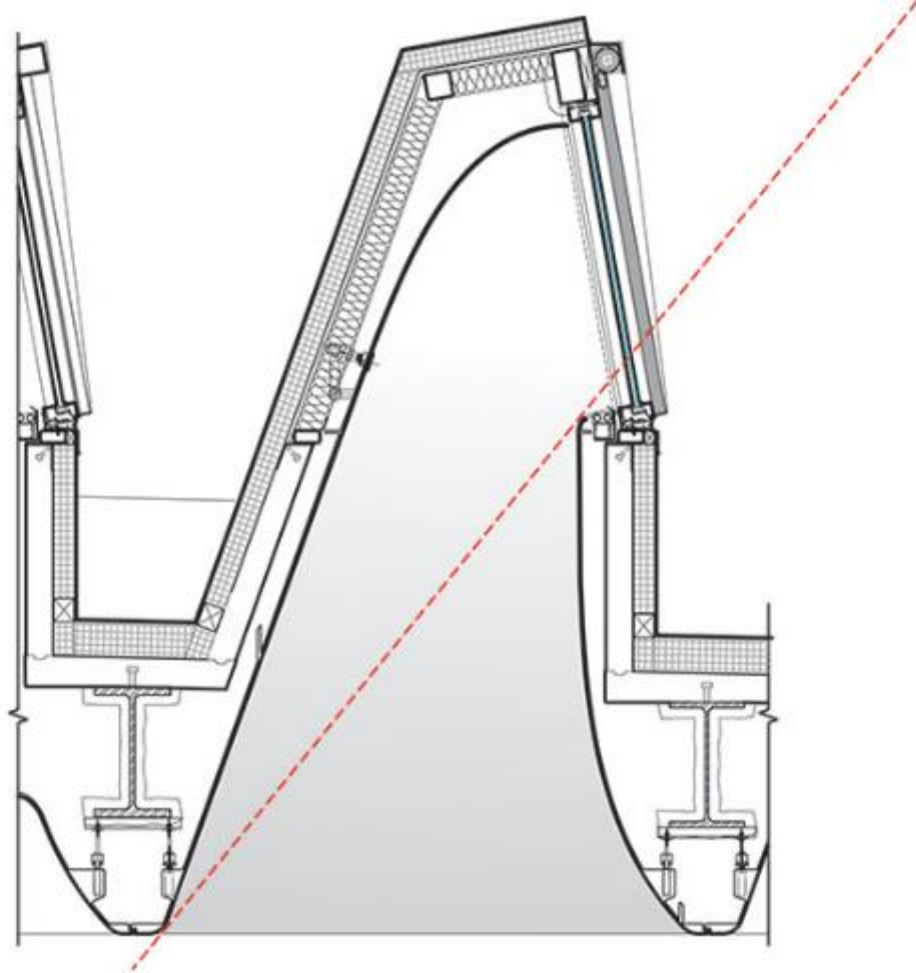

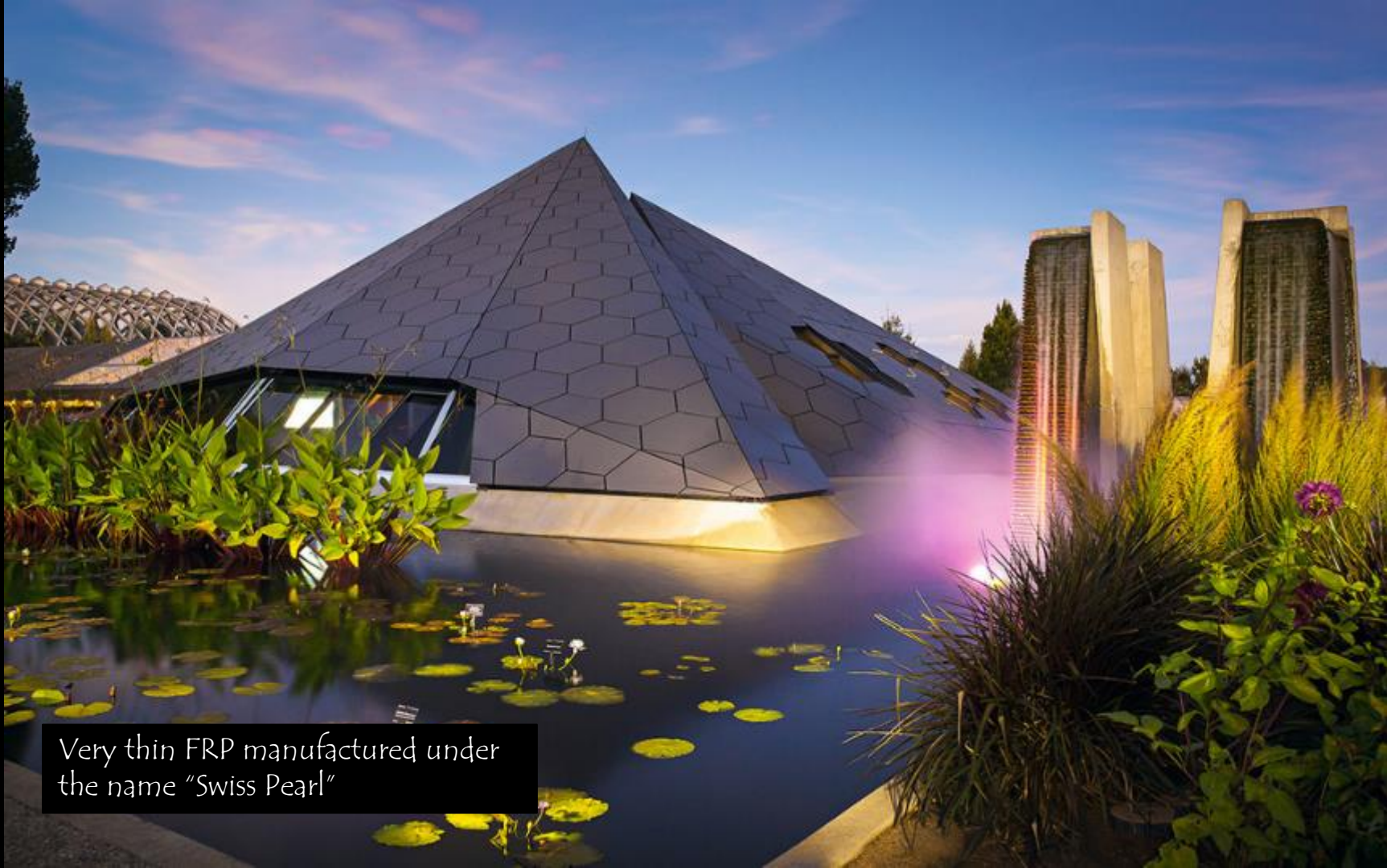

Very thin FRP manufactured under the name "Swiss Pearl"





















Horizontal section

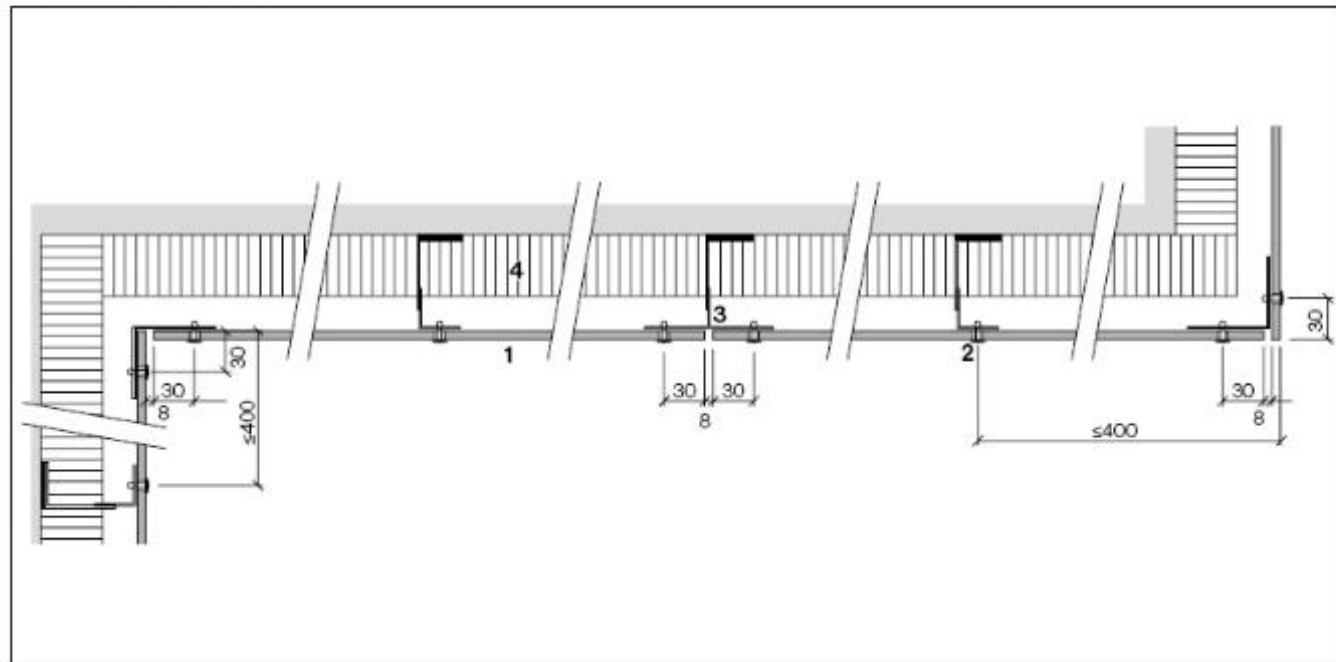

Panel may be cantilevered max.
400 mm.

- 1 Swisspearl panel 8 mm
- 2 Rivet
- 3 Aluminum profile
- 4 Thermal insulation

Design | Metal supports

Example window jamb

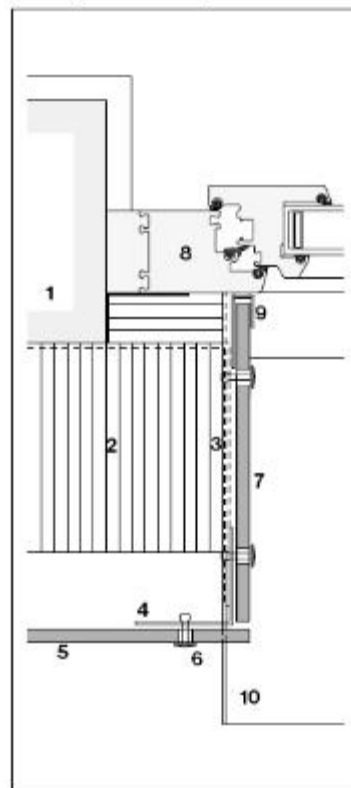

Jamb with 8 mm panel

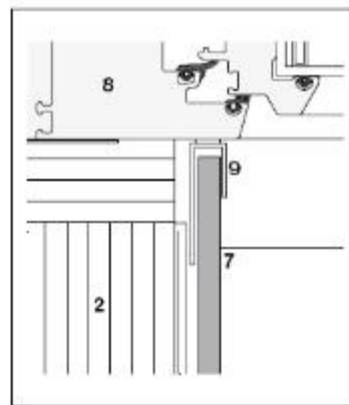

Window jamb with metal frame

- 1 Exterior wall
- 2 Thermal insulation
- 3 Horizontal support
- 4 Vertical support
- 5 Swisspearl panel 8 mm
- 6 Rivet 4.5x18 K15
- 7 Swisspearl jamb board 8 mm
- 8 Window frame
- 9 U or F-profile with sealant
- 10 Window sill

Example window sill

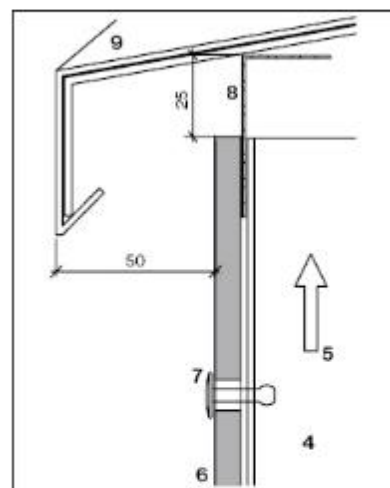
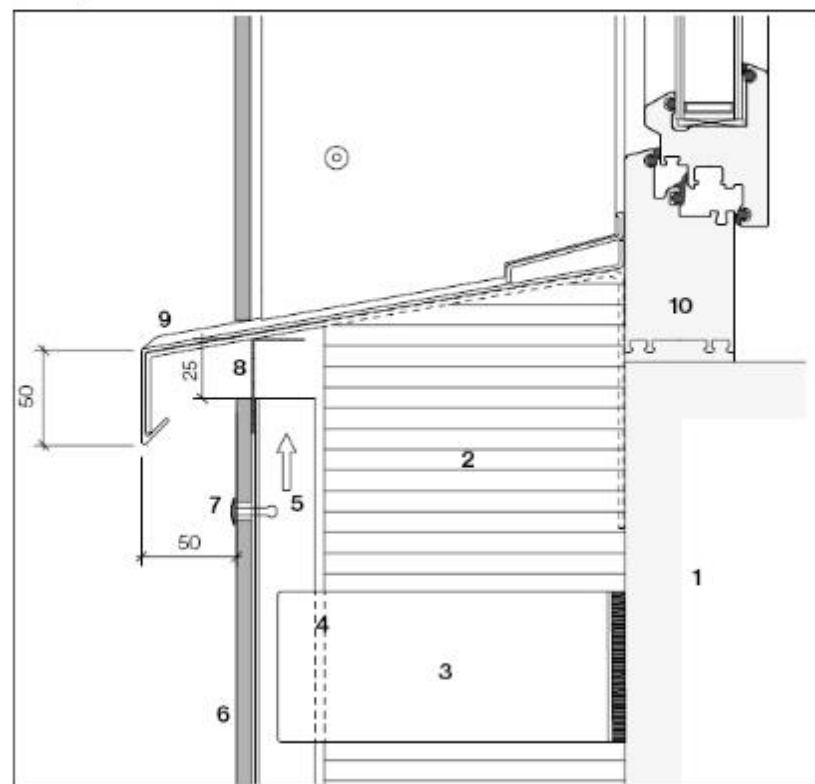

Sill detail

- 1 Exterior wall
- 2 Thermal insulation
- 3 Bracket
- 4 Vertical support
- 5 Ventilation cavity
- 6 Swisspearl panel 8 mm
- 7 Rivet 4.0×18-K15
- 8 Perforated angle
- 9 Window sill
- 10 Window frame

Ceramic Fritted Glass

Ceramic Fritted Glass:

- Silk screening onto glass improves solar control performance
- Can be combined with clear or tinted substrates
- Reduces glare
- Can be any pattern (cost dependent)



Chicago O'Hare International Airport









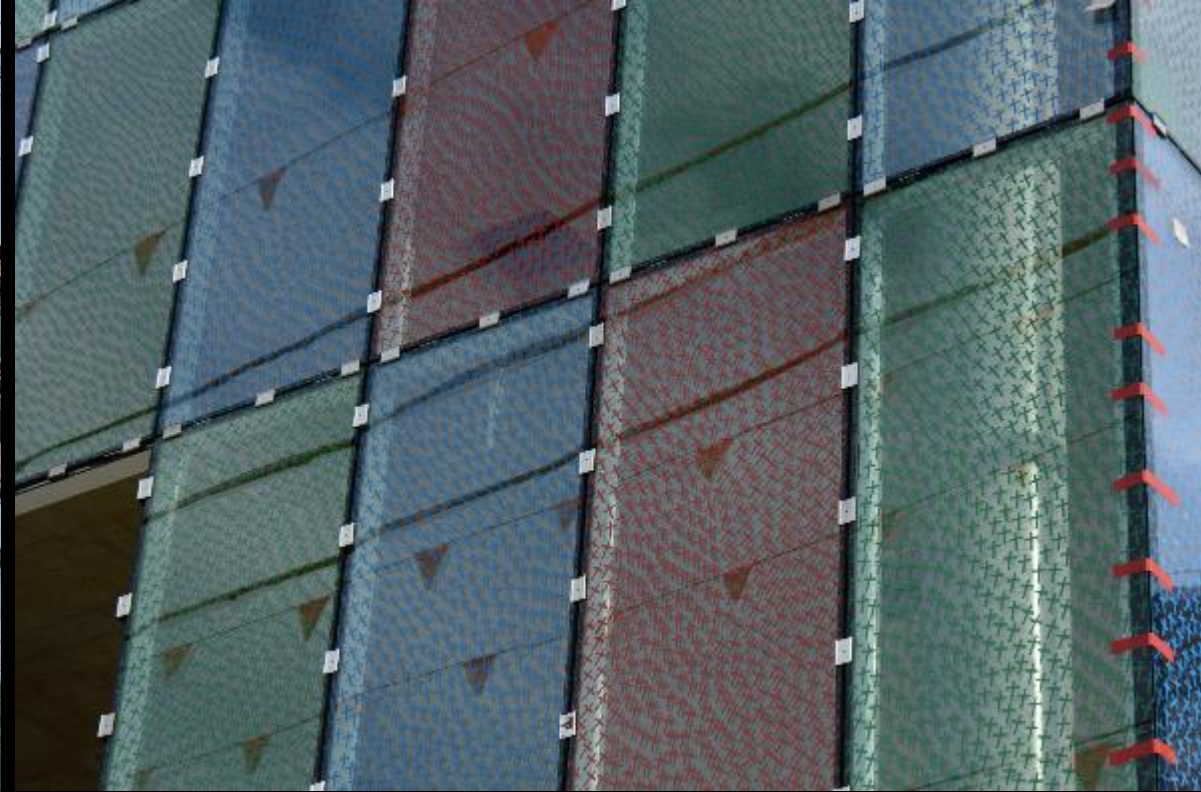





One New Change Shopping Centre
London, England
Ateliers Jean Nouvel













WATLING
STREET EC4







Office Building
Brisbane, Australia











Siemens HQ
Masdar City, Abu Dhabi, UAE
Sheppard Robson Architects
2013





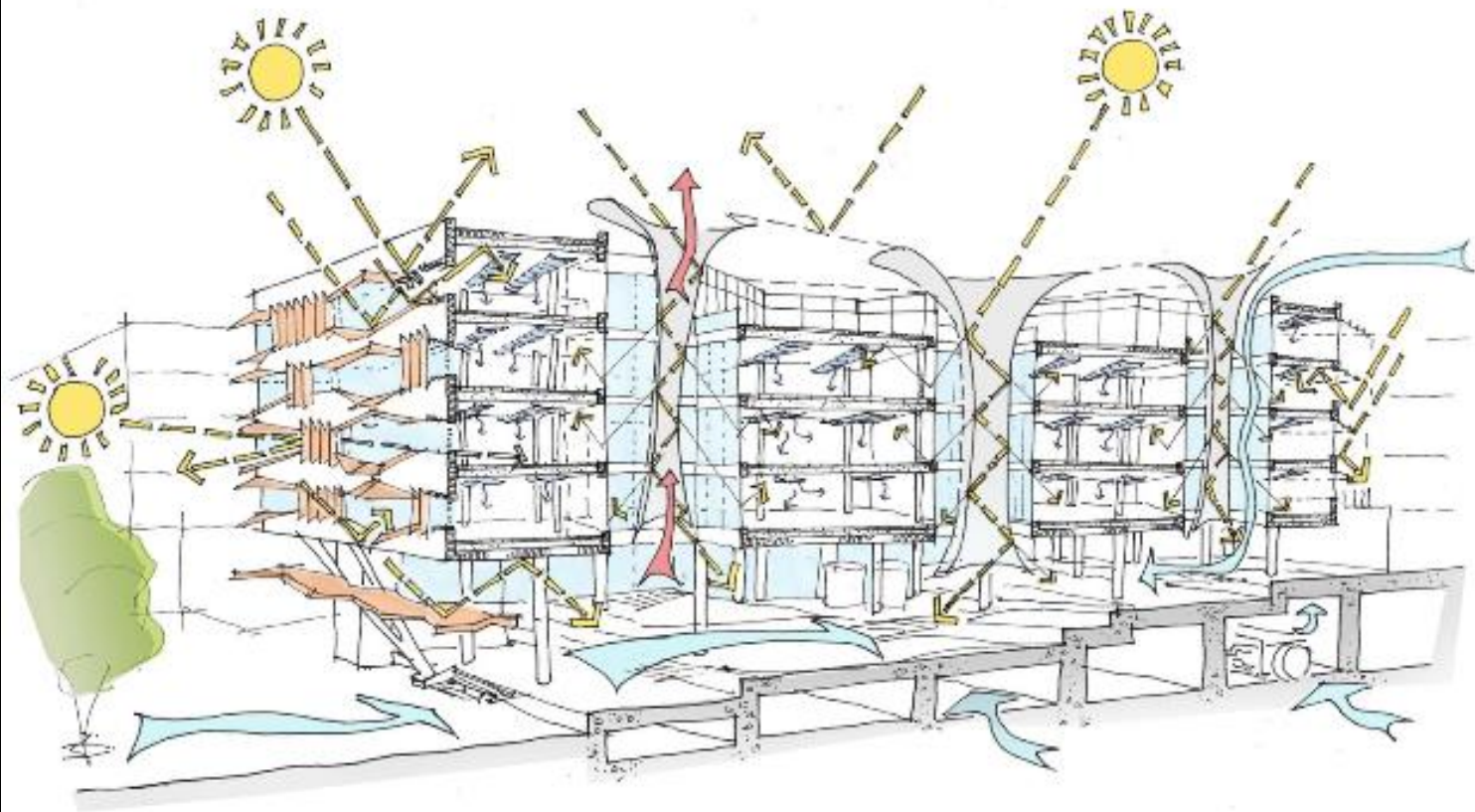

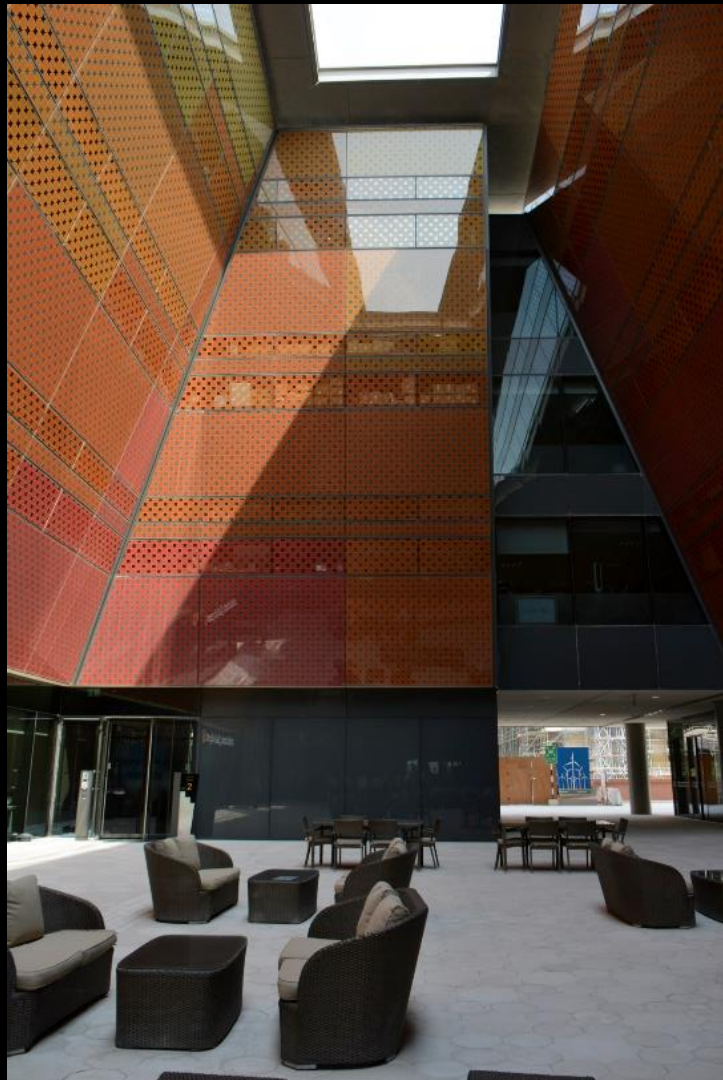





The Branley Museum
Paris, France
Ateliers Jean Nouvel











Billetterie  













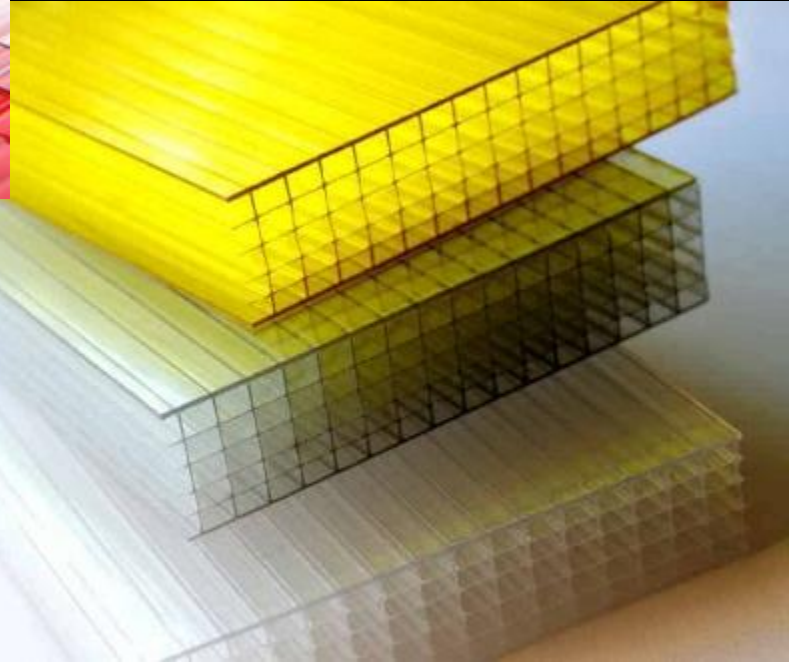
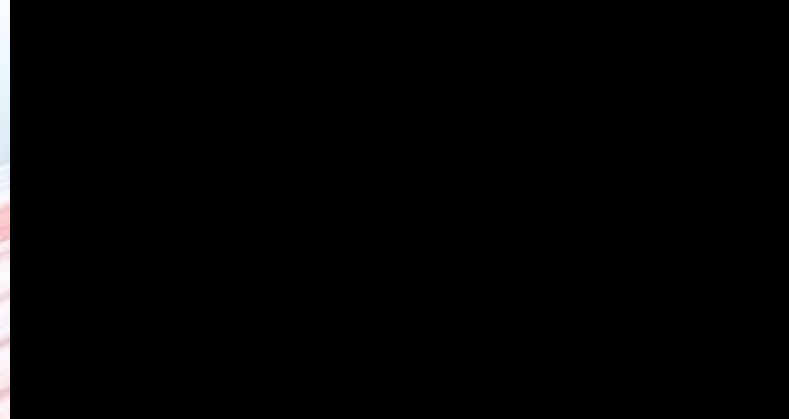
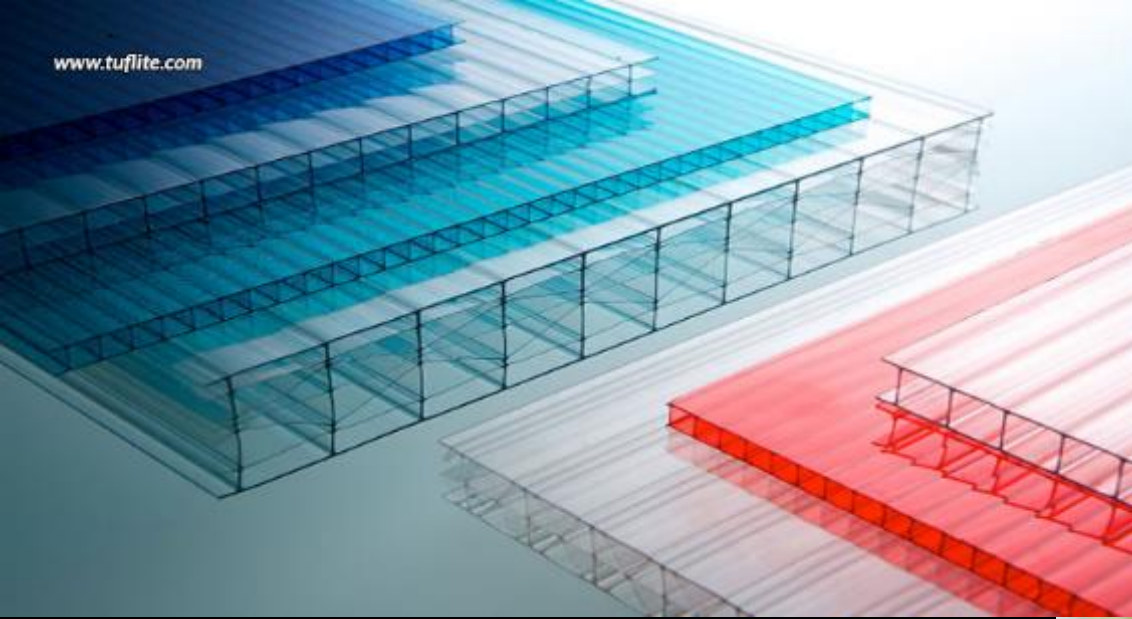

Polycarbonate Panels

<https://danpal.com/polycarbonate-panels/>



Trinity Laban Dance Centre
London, England
Herzog & deMeuron



















ETFE

Ethylene tetrafluoroethylene (ETFE) is a fluorine-based plastic. It was designed to have high corrosion resistance and strength over a wide temperature range. ... ETFE has a relatively high melting temperature and excellent chemical, electrical and high-energy radiation resistance properties.



The Water Cube
2008 Beijing Olympics





Eden Project
St. Austell, England
Nicholas Grimshaw





Japan National Pavilion
Shanghai Expo 2010





Parkview Green
Beijing, China

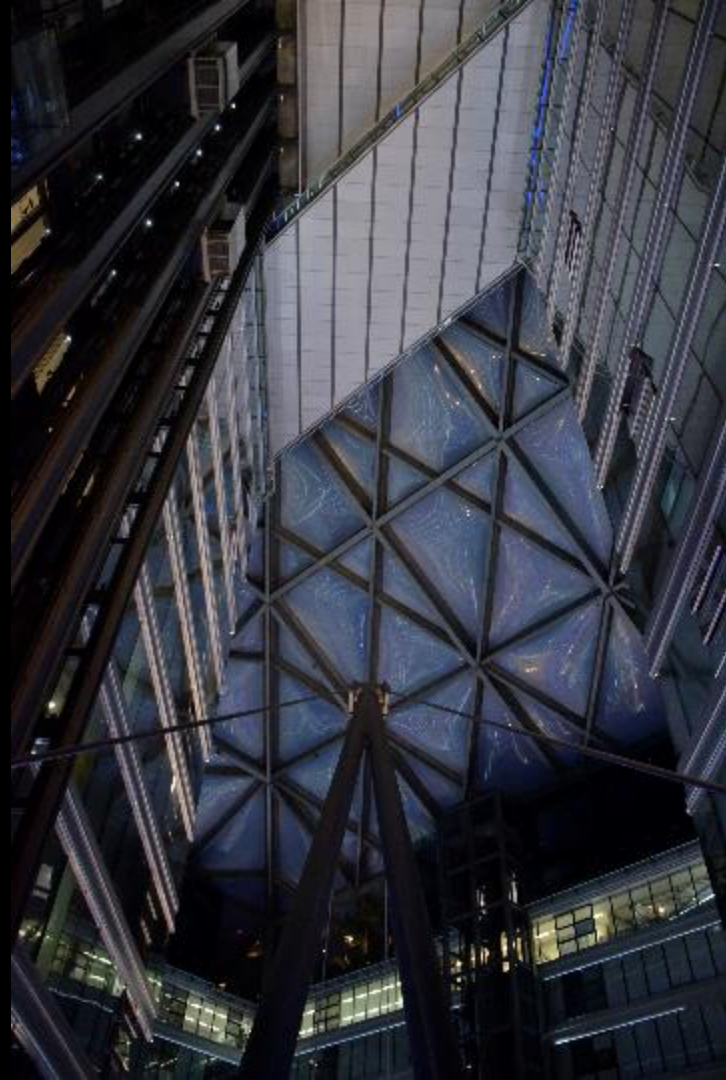





Allianz Arena
Munich, Germany

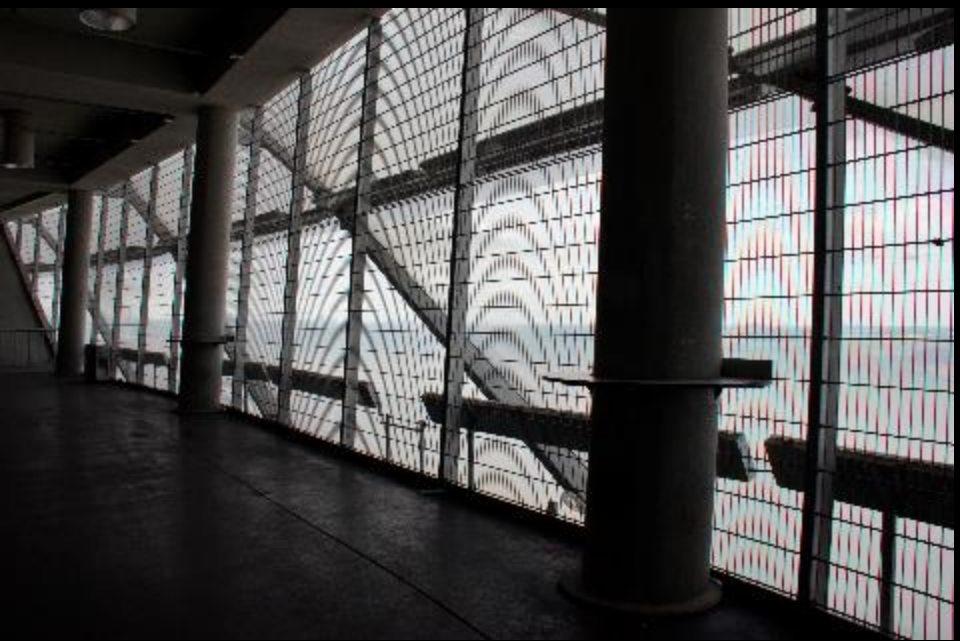

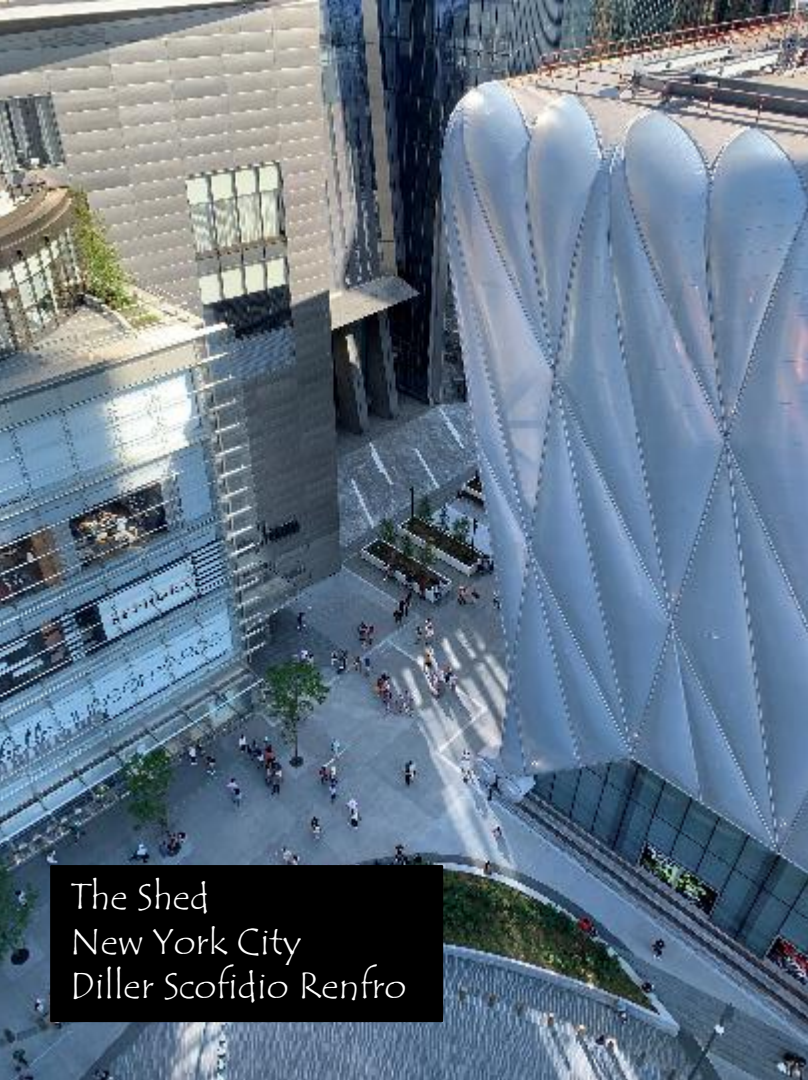

The Shed
New York City
Diller Scofidio Renfro

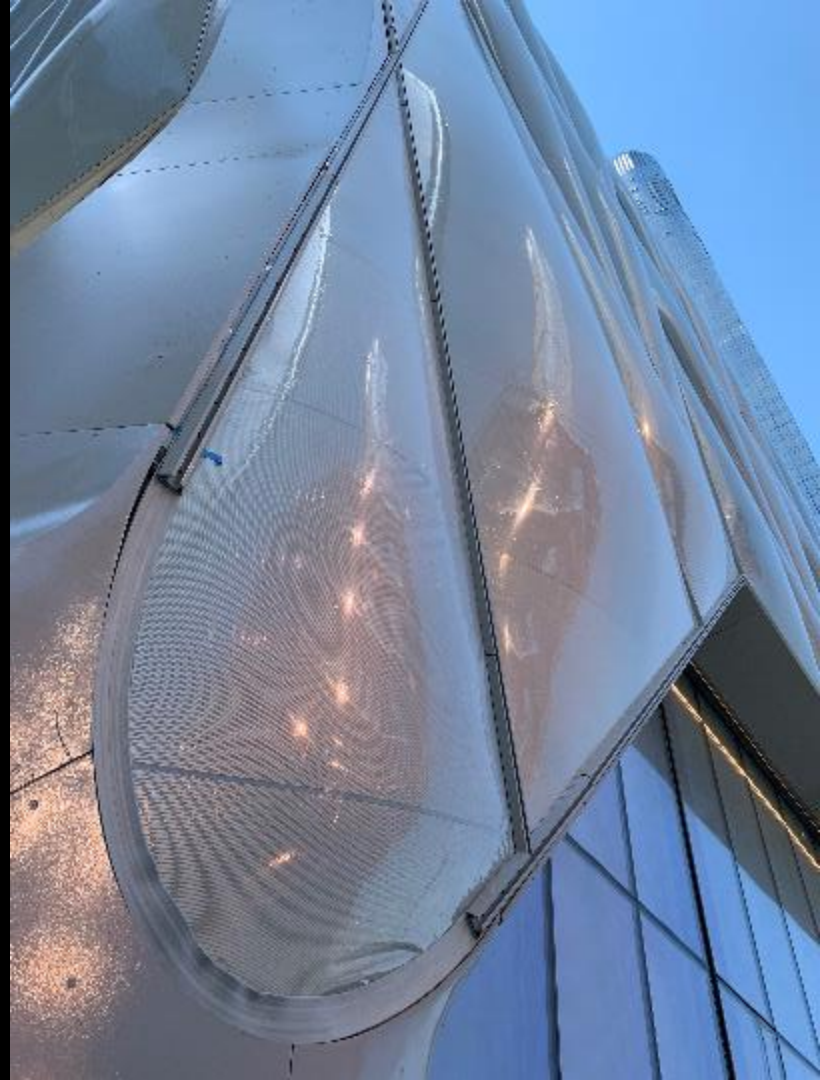



Generally the façade has evolved towards systems that are:

- Durable
- Lighter – so less mass, weight on foundations, carbon
- Higher R-values
- Made of multiple layers
- Using a rain screen/drainage plane
- External to the structural system to keep the structure at a constant temperature